

# MAJOR AUGMENTATION PROPOSAL

## OPTIONS PAPER

Picton South - Staged 132kV conversion

3 February 2020



**Prepared By:**

Grid Transformation

Western Power

GPO Box L921, Perth WA 6842

ABN 18 540 492 861

**DOCUMENT PURPOSE**

For the benefit of those not familiar with the Electricity Networks Access Code 2004, Western Power offers the following clarifications on the purpose and intent of this document:

1. Western Power, as a prudent electricity networks business, is required to carry out forward planning to identify future reliability of supply requirements and to issue this type of document for proposed “Major Augmentations” to the covered network;
2. The Electricity Networks Access Code 2004 requires that Western Power should properly assess each Major Augmentation to determine whether it maximises the “Net Benefit” to those who generate, transport or consume electricity, after considering alternative options; and
3. This document contains the results of this assessment, and a draft recommended solution to address future supply requirements in several stages of project implementation, starting from August 2020. Interested parties are invited to comment on the draft recommendation.

What the document does NOT mean:

4. It does NOT mean that the electricity supply interruptions are imminent. The identified supply interruption scenario is a moderate consequence event with possible likelihood, which has not been observed in the system during the past 10 years, with its likelihood expected to increase within the next 10 years. There is sufficient time to implement a solution with mitigation strategies in place to prevent any associated supply interruptions.
5. It does NOT mean that Western Power has been surprised. It is, in fact, part of the standard Western Power planning processes.

# Contents

|  |            |
|--|------------|
| <b>Glossary</b> .....  | <b>v</b>   |
| <b>Executive summary</b> .....   | <b>vii</b> |
| <b>1. Background</b> .....   | <b>xiv</b> |
| 1.1 Geographical Area - Bunbury Load Area.....   | xiv        |
| 1.2 Picton South Network.....  | xv         |
| 1.3 Network Strategy and Network Development Plan.....   | xvi        |
| 1.4 Developments in Peak Demand Forecast and Asset Condition.....  | xvii       |
| 1.5 Peak Demand Forecast.....  | 1          |
| <b>2. Asset Condition</b> .....  | <b>4</b>   |
| 2.1 Asset Condition Summary.....   | 4          |
| 2.2 Power Transformers.....  | 5          |
| 2.3 Primary Plant.....   | 6          |
| 2.4 Transmission Lines – Conductors.....   | 7          |
| 2.5 Transmission Lines – Structures.....   | 7          |
| <b>3. Planning Drivers</b> .....   | <b>9</b>   |
| 3.1 Planning Criteria.....   | 9          |
| 3.2 N-1 Criterion – Steady State Network Performance.....  | 9          |
| 3.3 Short Term Voltage Stability.....  | 9          |
| 3.4 Long Term Voltage Stability.....   | 10         |
| 3.5 Maximum Supportable Demand.....  | 10         |
| <b>4. Committed Projects</b> .....   | <b>11</b>  |
| 4.1 Present Projects.....  | 11         |
| 4.2 Completed Projects.....  | 11         |
| <b>5. Options Considered</b> .....   | <b>12</b>  |
| 5.1 Network Options.....   | 12         |
| 5.2 Non-Network Options.....   | 12         |
| 5.3 Key Assumptions.....   | 13         |
| 5.4 Development Strategy 1: Picton South 132kV conversion – Accelerated conversion.....                                      | 14         |
| 5.5 Development Strategy 2: Picton South 132kV conversion – Staged 132kV conversion -<br>Busselton Terminal Transformer..... | 17         |
| 5.6 Development Strategy 3: Picton South 132kV conversion – Staged 132kV conversion -<br>Picton Terminal Transformer.....    | 20         |
| 5.7 Development Strategy 4: Retain 66kV Network - Procure NCS.....   | 23         |

|            |   |            |
|------------|---|------------|
| 5.8        | Development Strategy 5: Retain 66kV Network – Install Additional Reactive Support ..... | 25         |
| 5.9        | Managing Risks Prior to Construction.....   | 27         |
| 5.10       | Comparison of Development Strategies .....  | 28         |
| <b>6.</b>  | <b>Format and Inputs to Analysis.....</b>   | <b>32</b>  |
| 6.1        | Regulatory Test Requirements .....  | 32         |
| 6.2        | Network Augmentation Costs.....   | 32         |
| 6.3        | Other .....   | 32         |
| <b>7.</b>  | <b>Financial Analysis .....</b>   | <b>33</b>  |
| 7.1        | Net Present Cost .....  | 33         |
| 7.2        | Cost Building Blocks .....  | 35         |
| 7.3        | Demand Growth.....  | 36         |
| <b>8.</b>  | <b>Conclusions .....</b>  | <b>38</b>  |
| <b>9.</b>  | <b>Draft Recommendation .....</b>   | <b>40</b>  |
| <b>10.</b> | <b>Consultation.....</b>  | <b>41</b>  |
|            | <b>Appendix A : Asset Condition Criterion.....</b>                                      | <b>A-1</b> |
|            | <b>Appendix B : Transmission Line Asset Information .....</b>                           | <b>B-1</b> |
|            | <b>Appendix C : Asset Base Rationalisation.....</b>                                     | <b>C-1</b> |
|            | <b>Appendix D : Asset Replacement Expenditure .....</b>                                 | <b>D-1</b> |
|            | <b>Appendix E : Demand Growth Sensitivity Analysis.....</b>                             | <b>E-1</b> |
|            | <b>Appendix F : Discounted Options .....</b>  | <b>F-1</b> |
|            | <b>Appendix G : Picton South Network Diagrams .....</b>                                 | <b>G-1</b> |
|            | <b>Appendix H : Existing and Proposed Fault Levels .....</b>                            | <b>H-1</b> |
|            | <b>Appendix I : Resupply of WSD .....</b>   | <b>I-1</b> |
|            | <b>Appendix J : Capel and Busselton 132kV Line Conversion Options .....</b>             | <b>J-1</b> |
|            | <b>Appendix K : Network Control Services - Assumptions.....</b>                         | <b>K-1</b> |
|            | <b>Appendix L : Technical Rules Requirements .....</b>                                  | <b>L-1</b> |
|            | <b>Appendix M : Western Power Reference Documents.....</b>                              | <b>M-1</b> |

## Glossary

The list of abbreviations and acronyms used throughout this document is shown below.

| Abbreviation / Acronym | Definition  |
|------------------------|---|
| AEMO                   | Australian Energy Market Operator   |
| CAPEX                  | Capital Expenditure   |
| CMD                    | Contract Maximum Demand   |
| CPI                    | Consumer Price Index  |
| CT                     | Current transformer   |
| DTC                    | Distribution Transfer Capacity  |
| DSM                    | Demand Side Management  |
| ERA                    | Economic Regulation Authority   |
| IEM                    | Investment Evaluation Model   |
| kV                     | Kilo Volt   |
| MRL                    | Mean Replacement Life   |
| MVA                    | Mega Volt Ampere  |
| MVAr                   | Mega Volt Ampere (Reactive)   |
| MW                     | Mega Watt   |
| MWh                    | Mega Watt-hour  |
| N-0                    | System normal state, operating with no transmission elements out of service |
| N-1                    | System state with one transmission element out of service                   |
| NCR                    | Normal Cyclic Rating  |
| NCS                    | Network Control Service   |
| NDP                    | Network Development Plan  |
| NFIT                   | New Facilities Investment Test  |
| NPC                    | Net Present Cost  |
| OPEX                   | Operating Expenditure   |
| pa                     | Per Annum   |
| PoE                    | Probability of Exceedance   |
| PV                     | Photo Voltaic   |
| RCP                    | Reserve Capacity Price  |
| VT                     | Voltage Transformer   |

|                                |  |
|--------------------------------|--|
| WACC                           | Weighted Average Cost of Capital         |
| WEM                            | Wholesale Electricity Market             |
| <b>Substation Abbreviation</b> | <b>Definition</b>                        |
| BSN                            | Busselton Substation                     |
| CAP                            | Capel Substation                         |
| MR                             | Margaret River Substation                |
| PIC                            | Picton Substation                        |
| WSD                            | Westralian Sands <sup>1</sup> Substation |

---

<sup>1</sup> The Westralian Sands substation is owned by Iluka Resources

# Executive summary

## Introduction

The Picton South network is a sub network of the Bunbury load area, spanning from Picton to Augusta. Approximately 46,000 customers are supplied within Picton South, with a mix of residential, commercial, industrial and agricultural electricity consumers.

One of Western Power's key overarching strategies that drives investment is Western Power's 66kV Rationalisation strategy. This strategy guides investment decisions related to the replacement of 66kV networks to maximise the net benefit for network Users and maintain appropriate asset types/volumes with respect to current and forecast network conditions.

The Picton South network is one of the few remaining pockets of Western Power's network still operating at a 66kV transmission voltage. A significant number of these assets are approaching or have already exceeded<sup>2</sup> their expected replacement life, with many assets also in degraded condition, resulting in multiple safety, reliability of supply and system security risks that have triggered the need for network development within the Picton South region.

The two 132/66kV Picton terminal transformers are 52 years old and in degraded condition, representing the highest risk assets in the area. These transformers are critical in providing supply to the entire Picton South 66kV network and are necessary to maintain N-1 system security to the region. The timely replacement of these transformers is required to avoid the initial loss of supply of up to approximately 46,000 customers (of which 81 are on life support), followed by significant periods of load shedding that will result in adverse impact on customers experience and reduced economic activity in the region<sup>3</sup>.

In addition, significant growth within the last 25 years has led to the 66kV network exceeding its intended design capability, resulting in existing voltage related N-1 non compliances that limit further growth opportunities in the area.

Western Power recognises the importance of reliable and secure electricity supply to customers and has completed planning investigations to identify the most prudent and efficient course of action to continue to meet the needs of its customers in the Picton South region.

This document outlines five medium to long term development strategies to augment the Picton South transmission network and achieve the following objectives:

- Address the existing and emerging asset condition risks;
- Address existing steady state and dynamic voltage stability non-compliances prescribed under the N-1 design criterion;
- Increase the maximum supportable demand to meet the long term forecast growth; and
- Align with Western Power's long term strategies (in particular, the 66kV Rationalisation strategy).

Western Power has prepared this Options Paper, in accordance with the requirements of chapter 9 of the Electricity Network Access Code 2004, for public consultation as part of the Regulatory Test process for a Major Augmentation Proposal to the Western Power network. The objective of the Options Paper is twofold:

<sup>2</sup> These assets have a depreciated value of zero and the capital costs associated with these assets have been fully recovered.

<sup>3</sup> Although an N-2 event is outside the planning criteria, Western Power considers it prudent to address these risks, given the current degraded condition and system security risks associated these transformers.

1. to inform the public, in general, and interested parties, in particular, of the Major Augmentation Proposal; and
2. to obtain input with regard to any additional or alternative considerations.

Key stakeholders are encouraged to submit opinions and to offer alternative solutions to those proposed by Western Power.

A summary of the outcomes of the public consultation and submission will be published as part of Western Power’s submission to the ERA for a Major Augmentation Proposal and associated Regulatory Test requirements.

## Network Issues

### Assets

Most of the assets within the Picton South region are supplied by 66kV rated equipment. A significant portion of these assets are approaching or have already exceeded their expected replacement life, with many assets also in degraded condition, requiring them to either be replaced, maintained, upgraded or decommissioned.

The key assets that require mitigation within the short to medium term relate to the following power transformer replacements, as shown in Table ES.1.

**Table ES.1: Key power transformer asset information**

| Substation | Plant # | Voltage     | Nameplate Capacity | Asset Health Condition <sup>4</sup> | Estimated remaining life | Age | Committed Replacement Plans <sup>5</sup>               |
|------------|---------|-------------|--------------------|-------------------------------------|--------------------------|-----|--|
| Busselton  | T1      | 66/22kV     | 15 MVA             | Poor                                | 6                        | 62  | N  |
|            | T2      | 66/22kV     | 19 MVA             | Failed                              | n/a                      | n/a | N  |
|            | T3      | 66/22kV     | 15 MVA             | Poor                                | 6                        | 62  | N  |
| Picton     | T1      | 132/66/22kV | 100 MVA            | Bad                                 | 5 <sup>6</sup>           | 52  | N  |
|            | T2      | 132/66/22kV | 100 MVA            | Bad                                 | 5 <sup>6</sup>           | 52  | N  |
|            | T3      | 66/22kV     | 27 MVA             | Bad                                 | 18                       | 51  | Y – 132/22kV replacement                               |
|            | T5      | 66/22kV     | 27 MVA             | Failed                              | 16                       | 52  | Y – 132/22kV replacement                               |
| Capel      | T1      | 66/22kV     | 19 MVA             | Bad                                 | 14                       | 54  | Y – Installation of an additional 132/22kV replacement |
|            | T3      | 66/22kV     | 19 MVA             | Poor                                | 15                       | 53  |  |

<sup>4</sup> Based on a Condition Based Risk Management (CBRM) health index

<sup>5</sup> See Section 4 for further detail on committed works

<sup>6</sup> Routine inspection and diagnosis of both transformers identified inherent manufacturing defects on both transformers (i.e. high resistance ‘hot joints’ on phase windings), which have been temporarily managed through retaping. As a result, the expected remaining life of both transformers has been reduced from 17 to 5 years. The timely replacement of these transformers represents the highest asset condition risk for the area.



The mitigation of the asset condition issues with both Picton terminal transformers are expected to provide the greatest impact into shaping the development strategies, with high network criticality levels associated with these transformers.

### **Voltage Capacity**

The Picton South region has several existing non-compliances relating to voltage capacity within the N-1 design criterion. These limitations are most sensitive to demand levels at the Busselton and Margaret River substations<sup>7</sup>. Under peak demand conditions and following the loss of the single 132kV supply into Busselton, existing voltage capacity issues arise relating to:

- Inadequate steady state voltages – Picton South’s 66kV network is susceptible to low voltages, excessive voltage step, and in the worst case, a complete loss of supply, or ‘blackout’, to the region.
- Short and long term voltage instability – The dynamic response of the Picton South network is insufficient in recovering short term voltages to acceptable levels following a contingency event.
- Maximum supportable demand - These voltage capacity constraints limit the ability to meet the forecast peak demand and connect additional load in the area. The existing Picton South maximum supportable demand is currently limited to 46MW. Based on the past 2 years of data, this level is exceeded for 2.1%<sup>8</sup> (or 184 hours) of the year and is expected to increase with forecast growth in the area.

### **Options Considered**

Aligned with the long term strategy in the Bunbury load area, the identified development strategies to address the range of network issues are based on the following two broad investment themes:

1. Conversion of the Picton South network to operate at 132kV; and
2. Retention of the existing 66kV network topology and asset base.

The development strategies proposed for the Picton South network have been developed with consideration of Western Power’s 25 year ‘Central’ peak demand forecasts (2017-2042).

As discussed in more detail in sections 2 and 2, Western Power has completed detailed planning studies in considering feasible network options to mitigate the multiple asset condition issues and voltage capacity limitations within the Picton South region over the long term. These studies include load flow analysis, dynamic and fault level studies as well as other technical assessments to determine the capacity delivered by various options that achieve network compliance and adequately mitigate the identified network risks.

Assessment of a range of network drivers and Western Power’s 25 year peak demand forecasts within the Picton South network over a 50-year evaluation period has led to the development of five discrete development strategies based on the broad themes that include both network and non-network solutions:

1. Picton South 132kV conversion
  - a. Accelerated 132kV conversion
  - b. Staged 132kV conversion - Busselton terminal transformer

<sup>7</sup> The level of supportable demand into Busselton and Margaret River will be used throughout the Options Paper as a baseline in defining the Picton South’s limitations and comparing network development strategies.

<sup>8</sup> Western Power currently manages this risk operationally by pre-contingently splitting the 66kV and 132kV networks into Busselton at demand levels lower than the actual stability limit. Although these temporary measures manage these risks, the network is not compliant and operating in an insecure state.

- c. Staged 132kV conversion - Picton terminal transformer
- 2. Retain 66kV network
  - a. Procure Network Control Services (NCS)
  - b. Install additional reactive power support

## Evaluation

The five capital investment development strategies shown in Table ES.2 were evaluated against a range of financial and technical performance metrics. The development strategies consider asset rationalisation, alignment to Western Power’s 66kV rationalisation strategy and increases to Picton South maximum supportable demand.

**Table ES.2: Financial and technical assessment of proposed development strategies**

| Dev Strategy | Description   | Total NPC (\$M)    | Asset Rationalisation –<br>Relative to Picton South 66kV asset base (+/) |          |         |             |               |               |                    | Max Supp. Demand   | Strategic Alignment (Yes/No) |
|--------------|---|--------------------|--|----------|---------|-------------|---------------|---------------|--------------------|--------------------|------------------------------|
|              |   |                    | STATCOM  | Capbanks | Reactor | Terminal Tx | Substation Tx | Primary Plant | Transmission Lines |                    |                              |
| 1            | Accelerated 132kV conversion                              | 156.1              | ↑<br>1   | ↑<br>2   | -<br>0  | ↓<br>1      | ↓<br>5        | ↓<br>75       | ↓<br>91km          | 84MW               | Yes                          |
| 2            | Staged 132kV conversion - Busselton terminal transformer  | 143.6              | ↑<br>1   | ↑<br>2   | -<br>0  | ↓<br>1      | ↓<br>5        | ↓<br>75       | ↓<br>51km          | 84MW               | Yes                          |
| 3            | Staged 132kV conversion - Picton terminal transformer     | 148.9              | ↑<br>1   | ↑<br>2   | -<br>0  | ↓<br>1      | ↓<br>5        | ↓<br>75       | ↓<br>51km          | 84MW               | Yes                          |
| 4            | Retain 66kV network – Procure NCS                         | 174.1 <sup>9</sup> | -<br>0   | -<br>0   | ↑<br>1  | -<br>0      | ↓<br>3        | ↓<br>11       | -<br>0             | 76MW <sup>10</sup> | No                           |
| 5            | Retain 66kV network – Install additional reactive support | 161.5              | ↑<br>1   | ↑<br>2   | -<br>0  | -<br>0      | ↓<br>3        | ↓<br>11       | -<br>0             | 73MW               | No                           |

The results of the options analysis identified Development Strategy 2 as the most efficient long term solution for the Picton South region. Western Powers four key objectives of safe, reliable, efficient and growth are also met under the Development Strategy 2 investment pathway.

This development strategy represents an optimised network plan that is lower in cost than a like for like replacement solution, providing additional benefits including asset rationalisation and increases to

<sup>9</sup> Total costs are expected to be higher as connection costs were not included. For more detail on the assumptions used, refer to Appendix K.

<sup>10</sup> The maximum supportable demand is determined by the summation of the capacity of the procured NCS (30MW) and the existing maximum supportable demand (46MW)

maximum supportable demand to support the forecast peak demand, while providing additional spare capacity to accommodate future growth opportunities in the region.

A sensitivity analysis<sup>11</sup> was undertaken to determine the impact of variations in cost (+/- 20%) and the 'Central' 25-year peak demand forecast (+46%/-37%) to test the robustness of the recommended pathway. The output of the sensitivity analysis has demonstrated an outcome consistent with the base case economic analysis, in that Development Strategy 2 is still seen to have the lowest NPC compared to the alternative development strategies presented.

## Conclusion

Based on the options analysis and Western Power's obligations under the Electricity Networks Access Code 2004 for major augmentations, Western Power recommends progressing the following investments under Development Strategy 2, being the recommended network development pathway:

### By 2022:

- Uprate of the Picton-Capel/ Westralian Sands 71 line to support future energisation at 132kV including:
  - Upgrade electrical fittings and post insulators to 132kV specification
  - 2.5km of earthwire along the Picton-Capel 71 and 72 line circuits
- Transfer Westralian Sands 66kV tee-line from Picton-Capel/Westralian Sands 71 to Picton-Capel 72 transmission line via the construction of a new 3km 132kV rated (energised at 66kV) wood pole single circuit with 'Lemon' conductors.

### By 2023:

- Extension of the existing 132kV busbar at Busselton substation, including a new 132kV disconnecter
- Installation of a new 132kV Tx bay and 100MVA 132/66/22kV transformer at Busselton substation

### By 2024:

- Installation of a static and dynamic reactive support at Busselton substation including:
  - Install 1 x (+/-) 12MVar of dynamic reactive support devices (i.e. STATCOM) and associated step-up transformer equipment
  - Install 10MVar capacitors and associated plant on 22kV tertiary winding of new Busselton 132/66kV transformer

The nominal<sup>12</sup> capital cost of this option being \$38.2 million is the subject of this Options Paper and subsequent Regulatory Test Submission. This cost has been determined as part of the detailed cost estimate process through Western Power's Estimation and Value Assurance Section.

The recommended development strategy is a key decision that sets the investment direction for the entire Picton South network to ensure that the asset condition and voltage capacity network issues are addressed in a timely manner, while also providing additional benefits of asset rationalisation and spare capacity to accommodate future growth beyond the forecast peak demand in the area.

Upon the completion of the individual investments in this first stage of investments, the system security and supply risks associated with a single Picton terminal transformer contingency to the Picton South area

<sup>11</sup> See Appendix E– Demand Growth Sensitivity Analysis for further detail

<sup>12</sup> Nominal cost – includes indirects, risk and escalation

will be addressed. Additionally, the network will achieve N-1 network compliance and the maximum supportable demand at Busselton and Margaret River will increase from 46MW to 73MW to ensure the forecast peak demand is met over the long term.

The remaining investments of the development strategy consist of further asset replacement works and the complete conversion of one of the existing 66kV line circuits to 132kV. Upon energisation of the second 132kV supply into Busselton, the security of supply risks associated with the loss of both Picton terminal transformers will be completely addressed. Furthermore, the completion of these works will provide additional benefits including further asset rationalisation and maximum supportable demand increases from 73MW to 84MW, providing enough spare capacity to accommodate future growth opportunities.

The recommended investment pathway has been developed based on the most current and available information. Although unlikely, if strong growth drivers begin to emerge in the short to medium term, the network development under Development Strategy 2 can be accelerated towards a third 132kV supply into Busselton, with the increase in costs expected to be similar to Development Strategy 1.

It should be noted that the subsequent investments within the recommended strategy are expected to be taken forward in due course and will undergo more detailed technical, economic, social and environmental assessments with the most current available information to further develop and refine these individual investments. In addition, the investments beyond the recommended scope works to be progressed may be subject to future Regulatory Tests.

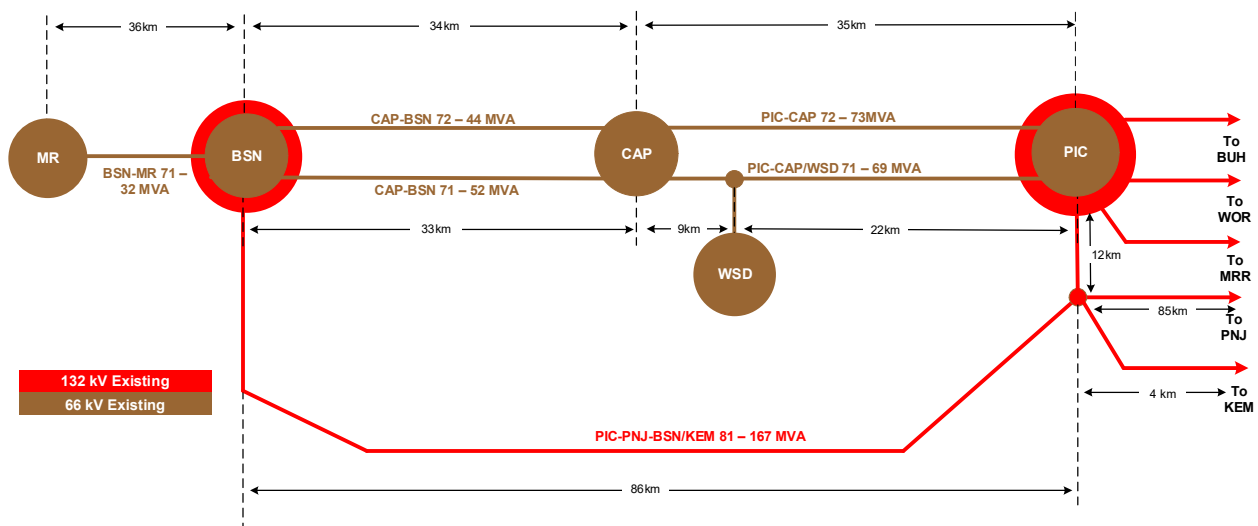

Figure 1: Existing Picton South network configuration

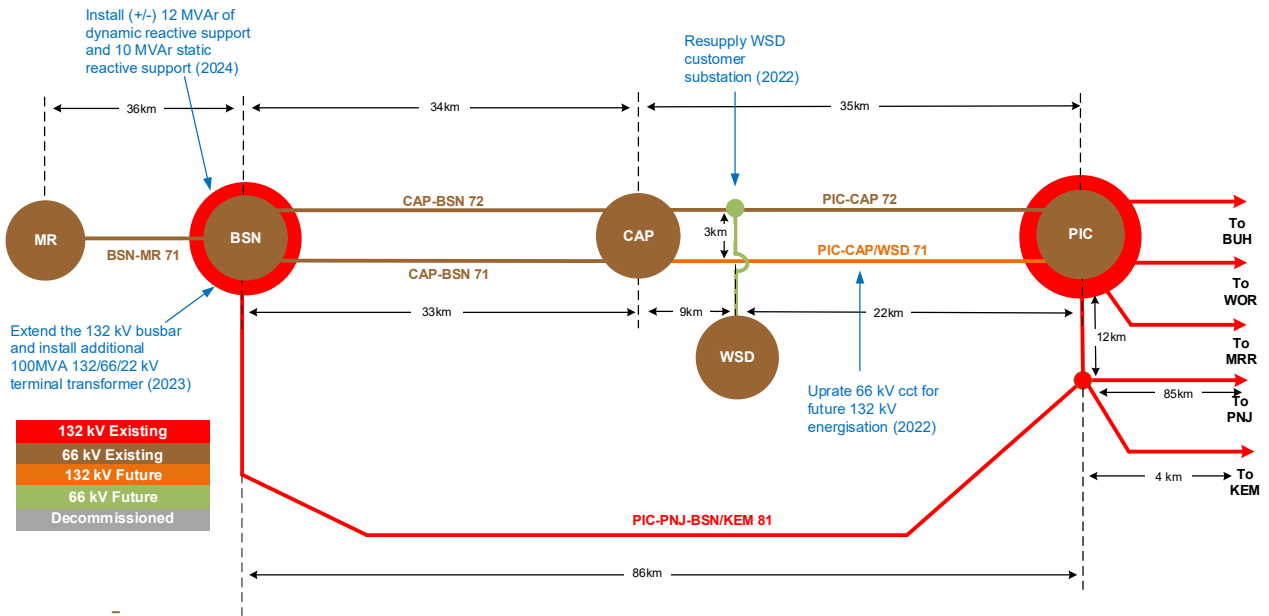

Figure 2: Development Strategy 2 – Stage 1 scope overview

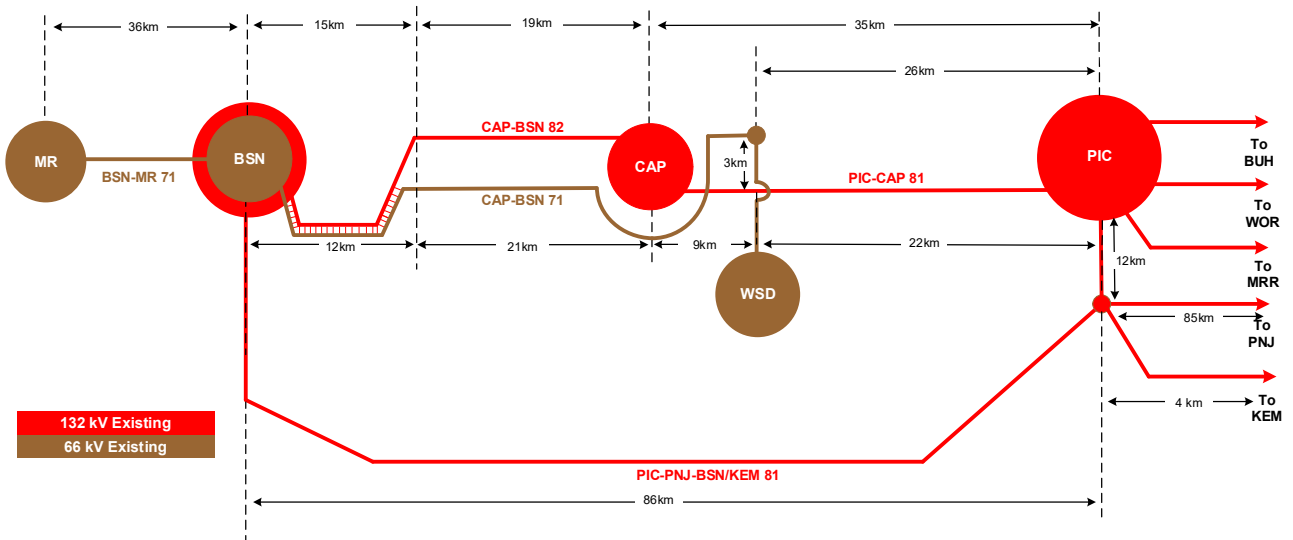

Figure 3: Development Strategy 2 – Final configuration

# 1. Background

## 1.1 Geographical Area - Bunbury Load Area

The Bunbury load area covers the south west corner of the Western Power network, stretching from Alcoa Pinjarra in the north to Augusta in the south and just West of Wagerup and Worsley.

Transmission network infrastructure in the region is illustrated below in Figure 4.

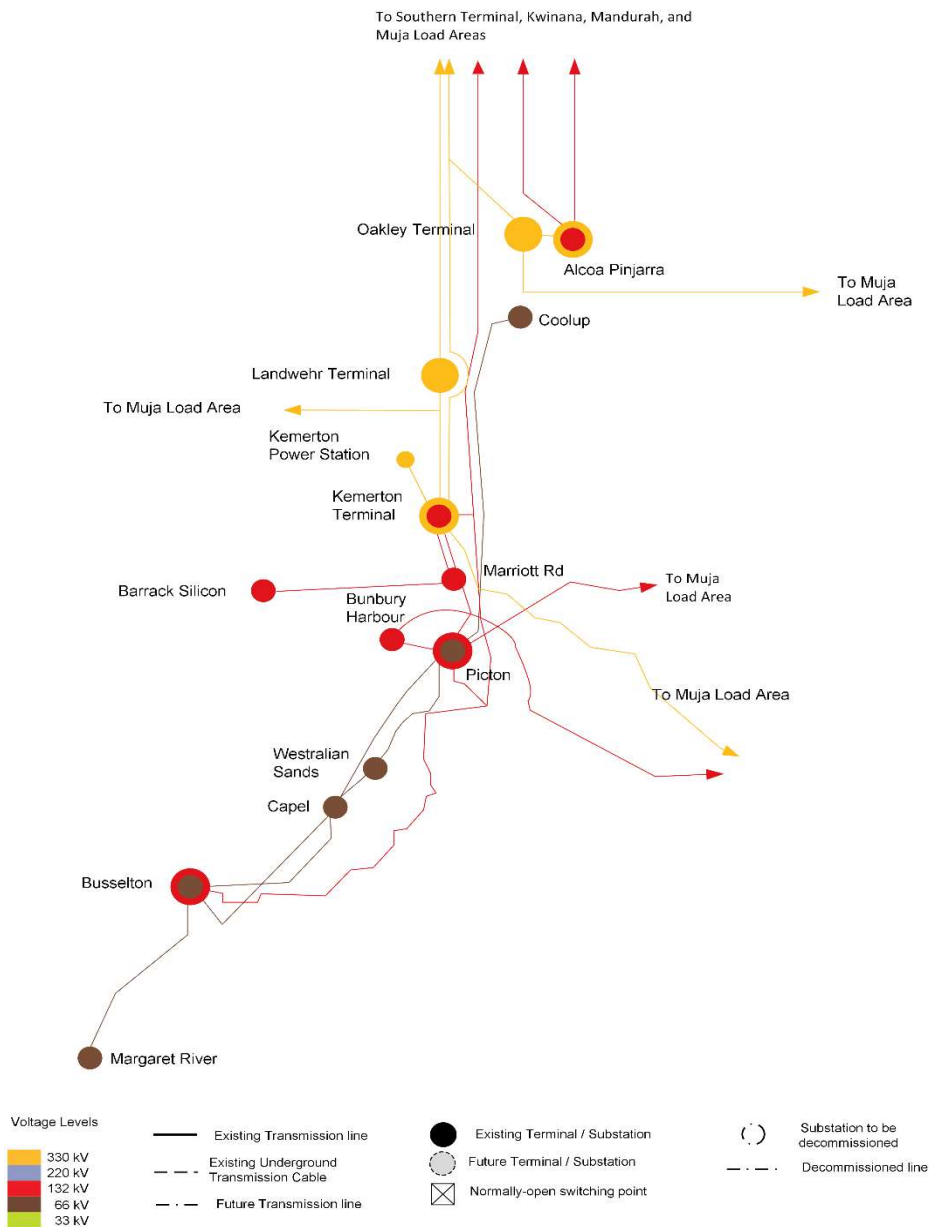

Figure 4: Bunbury load area

## 1.2 Picton South Network

The Picton South network supplies a subset of residential, commercial, agricultural and industrial customers in the Bunbury load area. The boundary for the transmission and distribution networks in this region is illustrated in Figure 5. The boundary envelops four Western Power owned substations (Picton, Capel, Busselton and Margaret River) and one customer owned substation (Westralian Sands) in the Capel region. Works in this area are the core focus of this options paper.

Electrically, the area is characterised as a lightly meshed network, consisting of two 66kV circuits emanating from the Picton terminal transformers and a long single 132kV supply into Busselton substation. Although Coolup substation is also supplied by the Picton terminal transformers, it has not been included in the options assessment due to the following reasons:

- Coolup is located north of Picton; and
- A committed project is currently in advanced stages of the planning phase, involving a series of distribution load transfers to the neighbouring Wagerup substation, facilitating the de-energisation of the Coolup substation by 2021 and decommissioning of the Coolup substation assets by 2024.

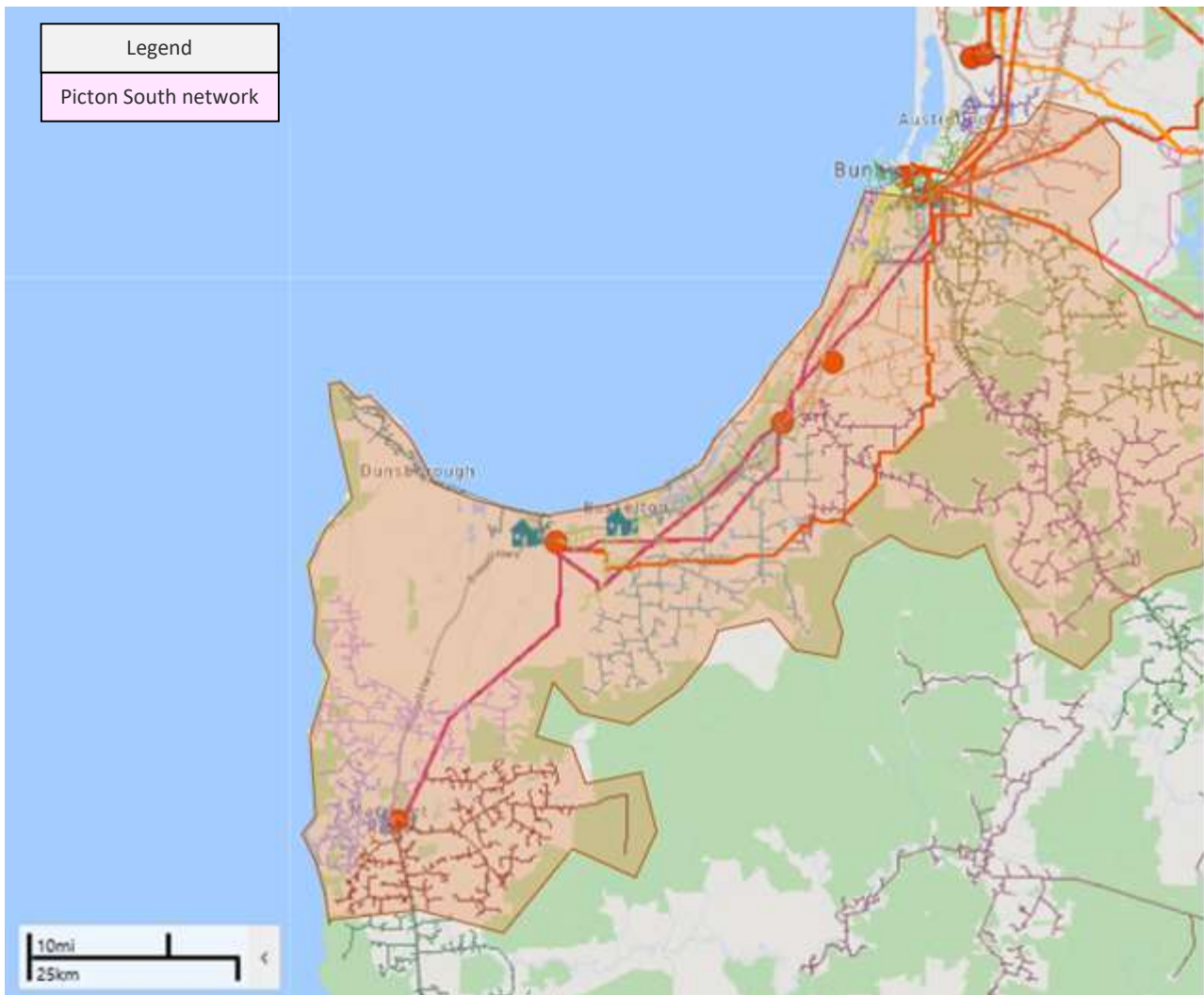

Figure 5: Picton South aerial overview

### 1.3 Network Strategy and Network Development Plan

The Picton South development plans take into consideration multiple relevant network strategies, the existing assets and network configuration within the Bunbury load area, in addition to proposed works described within 10 year Network Development Plan (NDP). This approach ensures consistency and demonstrates the network requirements over the longer term are well supported.

**Table 1.1: Relevant network strategies**

| Document  | Purpose   |
|---|---|
| 66kV Rationalisation strategy                         | A significant portion of Western Power’s 66kV networks are approaching or have already exceeded their expected replacement life, with many assets also in degraded condition, requiring assets to either be replaced, maintained, upgraded or decommissioned.<br><br>This strategy guides investment decisions related to the replacement of 66kV networks in order to maximise the net benefit for network Users and maintain appropriate asset types/volumes with respect to current and forecast network conditions.   |
| Bunbury load area long term strategy – 2017/18 update | The Bunbury load area long term strategy identifies individual investment projects to address specific individual drivers in the Bunbury load Area within a 25 year horizon.  |
| Bunbury load area long term staging report            | Western Power engaged an independent party to revisit and update the Bunbury long term plan. This document provided updates to the network strategy, following declining capacity drivers and accelerated asset condition risks (specifically relating to the Picton terminal transformers).<br><br>The updates focused on developing a more detailed staging of the works for the preferred Picton South investment pathway within a 10 year time horizon. It also included refining the accuracy of the cost estimates. |
| Network Development Plan (2016/17 – 2027/28)          | The purpose of the Network Development Plan is to identify the current and emerging transmission and distribution network limitations to forecast demand, compliance, customer, reliability, power quality and optimised asset condition network drivers over the period 2016/17 to 2027/28.<br><br>It also provides a summary of the proposed network and non-network plans to address these limitations and supports the forecast expenditure in the 10-year Business Plan (covering the period 2017/18 to 2027/28)     |

Based on the peak forecast data at the time, the Bunbury load area long term strategy - 2017/18 update document proposed network development in the Picton South region to include a third 132kV supply into Busselton by 2041, as illustrated in Figure 6.

The long term view also proposed maintaining Margaret River at 66kV for the foreseeable future, due to the lack of current capacity drivers to trigger voltage conversion upgrades. Should future capacity drivers emerge at Margaret River, suitable upgrade options will be investigated. However, it is important to note that changes to the supply voltage at Margaret River are not expected to have significant impact to the long term network development between Picton and Busselton.



The long term view also proposes the resupply of Westralian Sands Substation at 22kV. Although this supply arrangement is feasible, a more detailed assessment has been performed since to determine the most suitable supply arrangement for this customer owned substation<sup>13</sup>.

Figure 6 illustrates upgrading the existing supply lines to 132kV along the existing corridors, which is only indicative at this stage. The actual rebuilding of these circuits will largely depend how best to optimise the upgrades with asset condition drivers, while minimising cost and environmental impacts.

Since this document was developed, peak demand growth rates have reduced further, creating significant uncertainty around the need and timing for a third 132kV supply into Busselton.

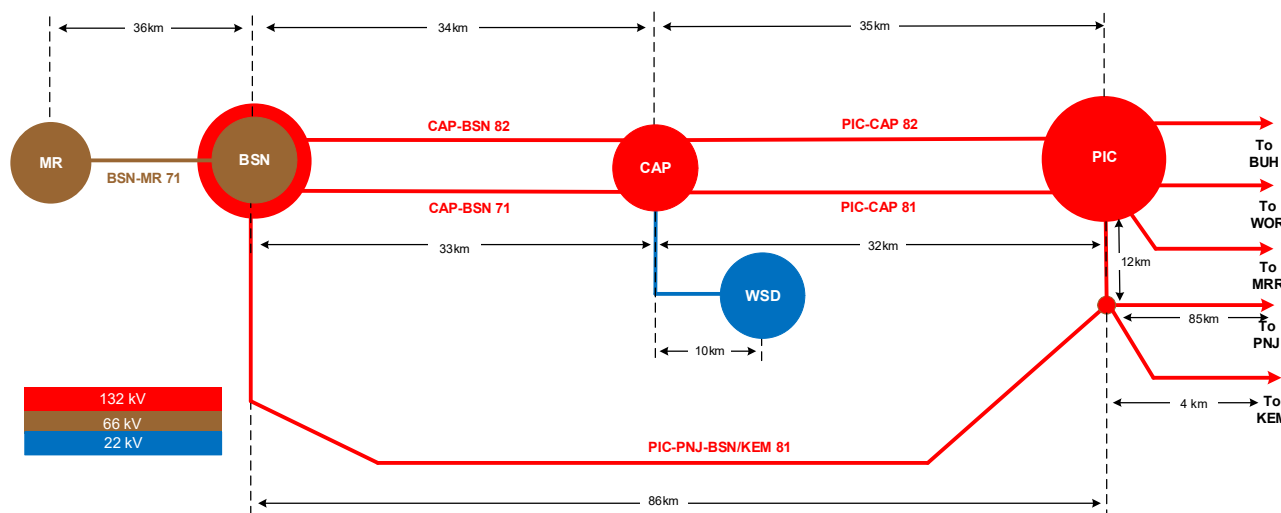

**Figure 6: Picton South Network Development – Long term strategic view**

## 1.4 Developments in Peak Demand Forecast and Asset Condition

The 25 year peak demand forecasts in the Bunbury load area are forecast to experience a slight increase in demand.

Historical peak demand forecasts have followed similar growth profiles, but higher growth trajectories in the past have been heavily revised down over several years due to external influencing factors, including, but not limited to:

- Declining economic conditions;
- Increased penetration of photovoltaic (PV) installations; and
- Increased appliance efficiencies.

<sup>13</sup> The Westralian Sands Substation supply arrangement assessment is discussed in more detail in Appendix I.

## 1.5 Peak Demand Forecast

The peak demand forecasts are a key input into Western Power system studies that identify existing and emerging network constraints on the Picton South transmission network.

During the development of this Options Paper, Western Power used the 2017 25 year peak demand forecasts being the latest approved forecasts. Western Power’s Forecasting team has contributed to the development of long term forecasts to support the ‘Whole of System Plan’ ongoing project which we have used to validate the 2017 peak demand forecasts. Following this review, the preferred option remains valid.

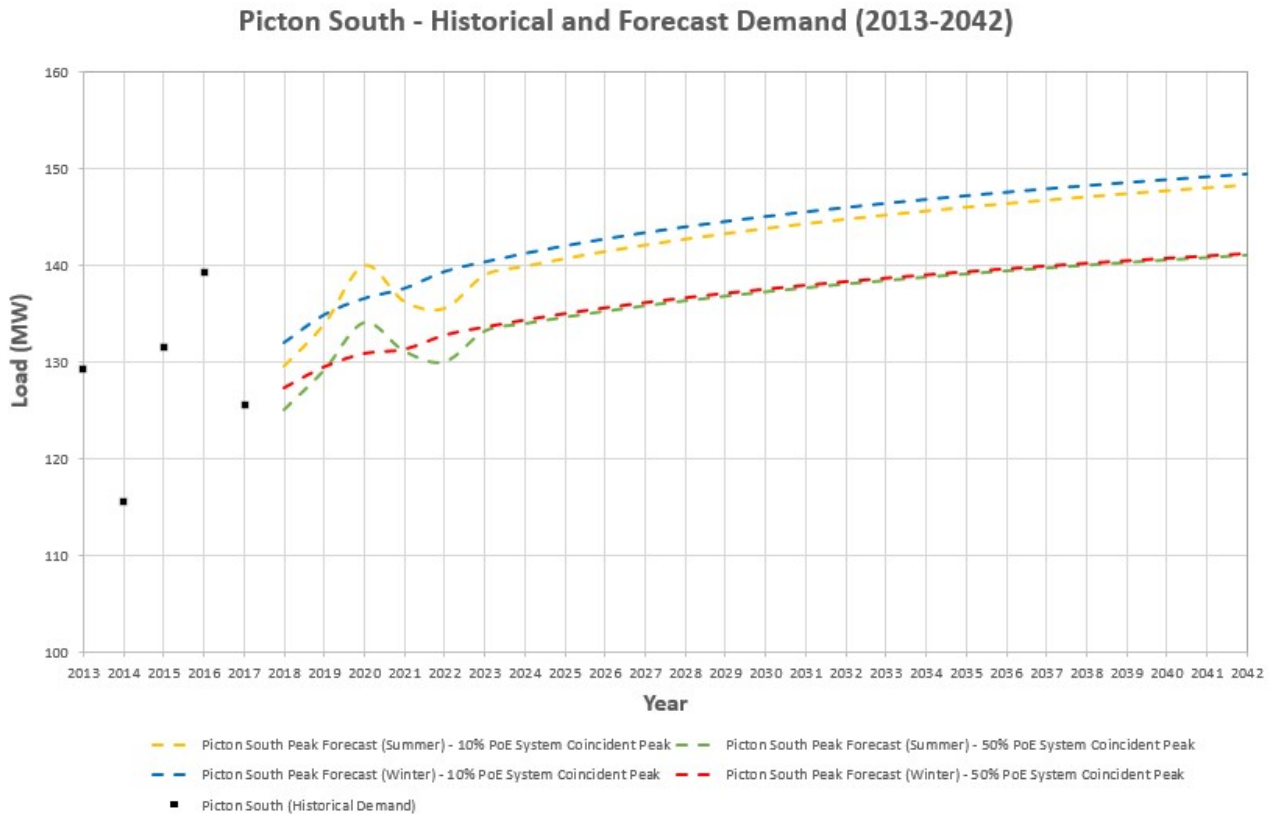

**Figure 7: Picton South region - 25 year ‘Central’ peak demand forecasts (MW)<sup>14</sup>**

The 25 year 2017 ‘Central’ PoE10% and PoE50% System summer and winter peak demand forecasts for the aggregated loads within the Picton South network are illustrated in Figure 7. The Picton South region is forecast to peak during winter periods. On a substation level, Capel and Busselton substations are summer peaking, whereas Picton and Margaret River are both winter peaking.

Table 1.2 highlights that the Picton South demand is expected to increase from 132.0MW to 149.3MW over the 25 year period, representing a moderate annual growth rate of 0.7%. Historically, the Picton South demand has been as high as 139.3MW, which is higher than the PoE10% Picton South System peak demand (winter) forecast up until 2023. Despite milder peak demand conditions in more recent years, higher historical demand indicate a level of latent demand that may be triggered by sustained periods of high temperatures.

<sup>14</sup> Coolup substation load is not included in the Picton South historical and forecast peak demand

**Table 1.2: Picton South region - 25 year peak demand forecasts (MW) – PoE10% System (Winter)<sup>15</sup>**

| Region       | 2018  | 2020  | 2022  | 2024  | 2026  | 2028  | 2030  | 2032  | 2034  | 2036  | 2038  | 2040  | 2042  |
|--------------|-------|-------|-------|-------|-------|-------|-------|-------|-------|-------|-------|-------|-------|
| Picton South | 132.0 | 136.6 | 139.3 | 141.2 | 142.7 | 143.9 | 145.0 | 145.9 | 146.7 | 147.5 | 148.1 | 148.8 | 149.3 |

While the forecast increase in peak demand in the region will not trigger new constraints in the region without a significant block customer load connection, the existing voltage capacity limitations described in detail in section 3 are expected to increase further due to growth forecast in the area over the long term.

In addition to peak demand forecasts, Western Power also considers minimum demand conditions to identify network constraints, which are shown in Table 1.3. Minimum demand conditions are modelled as portion of the peak demand forecasts.

**Table 1.3: Picton South region - 25 year minimum demand forecasts (MW) –PoE10% System (Winter)**

| Region       | 2018 | 2020 | 2022 | 2024 | 2026 | 2028 | 2030 | 2032 | 2034 | 2036 | 2038 | 2040 | 2042 |
|--------------|------|------|------|------|------|------|------|------|------|------|------|------|------|
| Picton South | 52.8 | 54.6 | 55.7 | 56.5 | 57.1 | 57.6 | 58.0 | 58.4 | 58.7 | 59.0 | 59.2 | 59.5 | 59.7 |

Table 1.4 highlights the PoE10% non-coincidental Substation peak demand forecasts at Busselton, Capel, Picton and Margaret River substations. These forecasts are non-coincident, meaning these loads represent the individual peak forecast demand of each substation, without regard to system demand, and are used to determine whether adequate substation capacity exists to cater for existing and future network demand.

Figure 8 shows that Capel substation is forecast to exceed its capacity in the presented planning horizon however, this capacity shortfall is only minor and will be addressed by committed works underway, as discussed in section 4. No other substations are expected to experience any capacity shortfalls.

<sup>15</sup> Western Power has also considered the Westralian Sands customer demand when performing network studies. This customer owned substation has a Contract Maximum Demand, which is not shown for confidential reasons.

Substation PoE 10% forecast

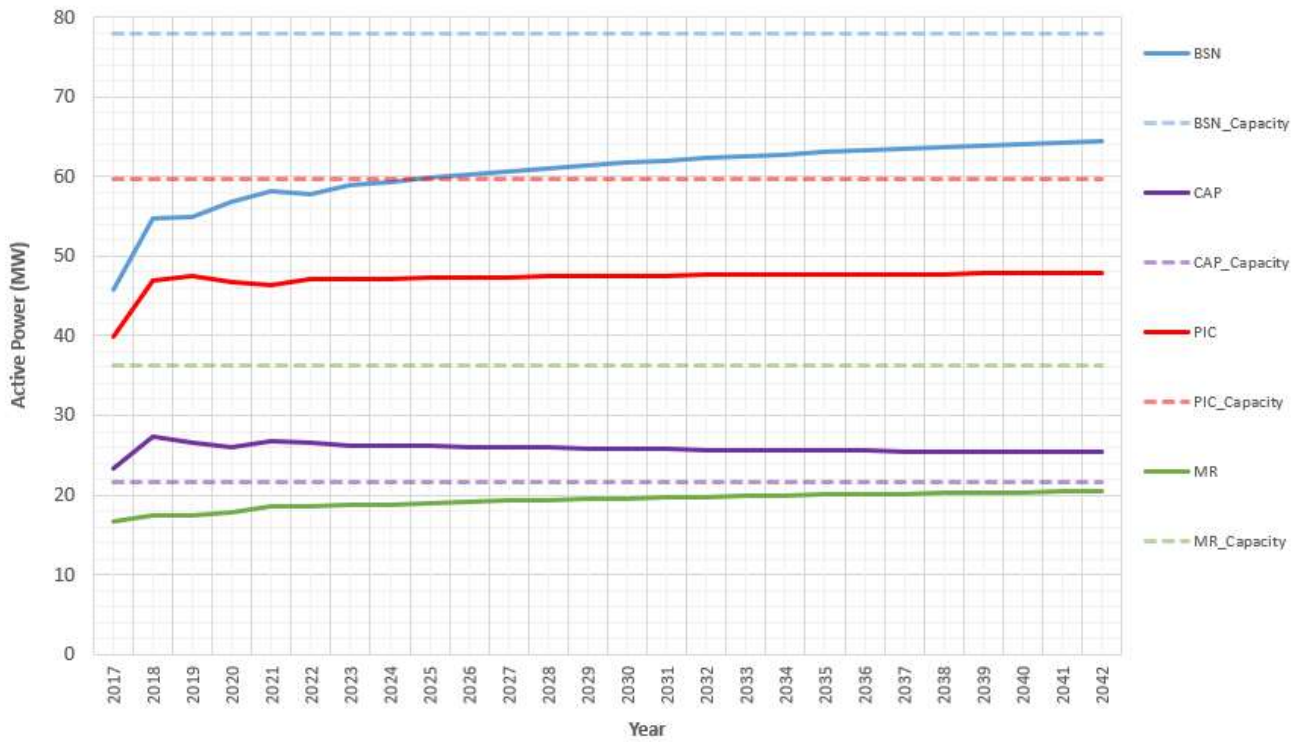

Figure 8: Picton South - 25 Year peak demand forecast - Substation (non-coincidental) PoE10%

Table 1.4: Picton South PoE10% Substation (non-coincident) peak demand forecast (MW) –

| Substation     | Sub Capacity (MVA) | Forecast Year |      |      |      |      |      |      |      |      |      |      |      |      |
|----------------|--------------------|---------------|------|------|------|------|------|------|------|------|------|------|------|------|
|                |                    | 2018          | 2020 | 2022 | 2024 | 2026 | 2028 | 2030 | 2032 | 2034 | 2036 | 2038 | 2040 | 2042 |
| Busselton      | 71.1               | 54.6          | 56.7 | 57.8 | 59.4 | 60.3 | 61.0 | 61.7 | 62.3 | 62.8 | 63.2 | 63.7 | 64.0 | 64.4 |
| Capel          | 21.6               | 27.4          | 26.0 | 26.6 | 26.2 | 26.0 | 25.9 | 25.8 | 25.7 | 25.6 | 25.6 | 25.5 | 25.4 | 25.4 |
| Picton         | 59.7               | 48.7          | 47.9 | 48.2 | 47.9 | 47.7 | 47.6 | 47.5 | 47.4 | 47.3 | 47.2 | 47.1 | 47.1 | 47.0 |
| Margaret River | 36.3               | 15.5          | 15.2 | 16.5 | 16.3 | 16.5 | 16.7 | 16.8 | 17.0 | 17.1 | 17.2 | 17.3 | 17.4 | 17.4 |

## 2. Asset Condition

As shown in Table 2.1, all Western Power substations within Picton South have been established around 1960, with one Customer substation established in 1987. A significant number of substation assets are approaching or have already exceeded their expected replacement life, with many assets also in degraded condition, resulting in multiple safety, reliability of supply and security risks in the region. As per Western Power's Planning Standard, assets are replaced based on their condition and criticality to the network. Asset replacements consider multiple network drivers to ensure optimised long term replacement plans are developed.

**Table 2.1: Picton South substation – Year commissioned**

| Substation Name  | Year Commissioned |
|------------------|-------------------|
| Margaret River   | 1956              |
| Busselton        | 1960              |
| Picton           | 1962              |
| Capel            | 1964              |
| Westralian Sands | 1987              |

Westralian Sands is a customer owned substation supplying Iluka North Capel mining operations. Western Power has engaged this customer to understand and align future planning requirements, where possible. At this stage, there are no changes to the customers' requirements in terms of the level of supply and service.

### 2.1 Asset Condition Summary

Most of the transmission assets within the Picton South region are rated at 66kV voltage, except for the 132/66kV terminal transformers at Picton and Busselton and two 132/22kV zone substation transformers at Busselton.

A significant portion of these 66kV assets are approaching or have already exceeded their expected replacement life, with many assets also in degraded condition. The 52 year old Picton terminal transformers present the most immediate risk, as they supply the entire 66kV Picton South network and are necessary to maintain N-1 system security to the region.

The Picton, Capel and Busselton supply and substation assets also have a significant volume of asset condition issues that require addressing within the next 10 to 20 years. The condition assessments at these substations were undertaken but limited to the following assets as they are the most material in terms of investment options and financial impact.

- Power transformer<sup>16</sup> – terminal and zone substation transformers
- Primary Plant<sup>17</sup> - circuit breakers, disconnectors, CT's and VT's
- Transmission Lines – conductors

<sup>16</sup> Power transformer and are large, bulky, long lead time assets with high replacement costs, which generally present opportunities to optimise replacement plans with other network drivers, such as demand.

<sup>17</sup> Primary plant assets and transmission line structures are modular in nature, allowing these assets to be replaced individually under large volumetric like for like programs.

- Transmission Lines – structures

Underpinned by Western Power’s 66kV Rationalisation strategy, an opportunity exists to develop an optimised network plan to address the safety and reliability of supply risks, while securing the long term system security in the Picton South region.

Western Power replaces assets using a risk-based approach which considers condition<sup>18</sup>, likelihood of failure and consequence of failure. Where available, individual asset information and the condition of the assets have been taken into consideration within the Option’s Paper’s analysis.

## 2.2 Power Transformers

Table 2.2 summarises the current condition and other key asset information for the power transformers in the Picton South region (excluding Margaret River), including any replacement plans that are at a committed stage.

**Table 2.2: Picton South - Power transformers**

| Substation | Plant # | Voltage     | Nameplate Capacity | Asset Health Condition <sup>19</sup> | Estimated remaining life | Age | Committed Replacement Plans <sup>20</sup>              |
|------------|---------|-------------|--------------------|--------------------------------------|--------------------------|-----|--|
| Busselton  | T1      | 66/22kV     | 15 MVA             | Poor                                 | 6                        | 62  | N  |
|            | T2      | 66/22kV     | 19 MVA             | Failed                               | n/a                      | n/a | N  |
|            | T3      | 66/22kV     | 15 MVA             | Poor                                 | 6                        | 62  | N  |
|            | T4      | 132/66/22kV | 100 MVA            | Good                                 | 52                       | 16  | N  |
|            | T5      | 132/22kV    | 33 MVA             | Good                                 | 55                       | 13  | N  |
|            | T6      | 132/22kV    | 33 MVA             | Good                                 | 62                       | 6   | N  |
| Picton     | T1      | 132/66/22kV | 100 MVA            | Bad <sup>21</sup>                    | 5 <sup>21</sup>          | 52  | N  |
|            | T2      | 132/66/22kV | 100 MVA            | Bad <sup>21</sup>                    | 5 <sup>21</sup>          | 52  | N  |
|            | T3      | 66/22kV     | 27 MVA             | Bad                                  | 18                       | 51  | Y – 132/22kV replacement                               |
|            | T4      | 66/22kV     | 33 MVA             | Good                                 | 51                       | 18  | N  |
|            | T5      | 66/22kV     | 27 MVA             | Failed                               | 16                       | 52  | Y – 132/22kV replacement                               |
| Capel      | T1      | 66/22kV     | 19 MVA             | Bad                                  | 14                       | 54  | Y – Installation of an additional 132/22kV replacement |
|            | T3      | 66/22kV     | 19 MVA             | Poor                                 | 15                       | 53  |  |

<sup>18</sup> See Table A.1 in Appendix A for further detail

<sup>19</sup> Based on a Condition Based Risk Management (CBRM) health index

<sup>20</sup> See section 4 for further detail on committed works

<sup>21</sup> Routine inspection and diagnosis of both transformers identified inherent manufacturing defects on both transformers (i.e. high resistance ‘hot joints’ on phase windings), which have been temporarily managed through retaping. As a result, the expected remaining life of both transformers has been reduced from 17 to 5 years.

In addition to the safety and reliability of supply risks associated with the Picton terminal transformers, these assets are critical in providing supply to the entire 66kV Picton South network and are necessary to maintain N-1 system security to the region. Without adequate mitigation, the eventual failure of both these transformers will result in the initial loss of up to approximately 46,000 customers supplied within the region (of which 81 are on life support), followed by significant periods of rotational load shedding that result in adverse impact on customers experience and reduced economic activity in the area.

## 2.3 Primary Plant

Table 2.3 lists the following key primary plant equipment information within the Picton South network:

- Circuit breakers
- Disconnectors
- CT's
- VT's

With no significant asset or growth drivers, Margaret River substation is expected to stay at 66kV for the foreseeable future. The asset information has therefore been excluded from this table the costings.

**Table 2.3: Picton South - Primary plant summary**

| Substations | Asset Type             | Total | Ave Age (yrs) | MRL (yrs) | # Beyond MRL | % at end of life |
|-------------|------------------------|-------|---------------|-----------|--------------|------------------|
| Busselton   | Circuit Breakers - Oil | 4     | 58            | 41        | 4            | 100              |
|             | Circuit Breakers – SF6 | 4     | 14            | 33        | 0            | 0                |
|             | Disconnectors          | 18    | 38            | 53        | 0            | 0                |
|             | CTs (per phase)        | 27    | 14            | 40        | 0            | 0                |
|             | VTs (per phase)        | 9     | 14            | 40        | 0            | 0                |
| Capel       | Circuit Breakers - Oil | 5     | 45            | 41        | 5            | 100              |
|             | Circuit Breakers – SF6 | 1     | 8             | 33        | 0            | 0                |
|             | Disconnectors          | 12    | 47            | 53        | 0            | 0                |
|             | CTs (per phase)        | 12    | 11            | 40        | 0            | 0                |
|             | VTs (per phase)        | 6     | 11            | 40        | 0            | 0                |
| Picton      | Circuit Breakers - Oil | 2     | 48            | 41        | 2            | 100              |
|             | Circuit Breakers – SF6 | 7     | 13            | 33        | 0            | 0                |
|             | Disconnectors          | 16    | 45            | 53        | 2            | 12.5             |
|             | CTs (per phase)        | 18    | 22            | 40        | 3            | 16.7             |
|             | VTs (per phase)        | 12    | 33            | 40        | 6            | 50               |

## 2.4 Transmission Lines – Conductors

Transmission line conductors have an expected life of 80 years. Table 2.4 below provides a summary of key information relating to the ratings, average age and condition for conductor assets within the Picton South line circuits.

The key transmission line conductor and structure data for the transmission line circuits between Picton and Busselton have been profiled in relation to their distribution along the line circuits within Appendix B.

**Table 2.4: Picton South transmission line circuits – Conductors**

| Transmission Line                               | Length (km) | Line Rating (A) |            | Conductor Type | Ave Age (yrs) | Voltage (kV) | Rated for 132kV (Y/N)? | Overall average condition |
|---|-------------|-----------------|------------|----------------|---------------|--------------|------------------------|---------------------------|
|   |             | Summer (A)      | Winter (A) |                |               |              |                        |                           |
| Picton-Capel/Westralian Sands 71                | 31.89       | 639             | 737        | Lemon          | 31            | 66           | Y <sup>22</sup>        | Good                      |
| Picton-Capel 72                                 | 34.79       | 639             | 737        | Lemon          | 42            | 66           | N                      | Fair                      |
| Capel-Busselton 71                              | 33.05       | 453             | 591        | Lemon          | 41            | 66           | N                      | Fair                      |
| Capel-Busselton 72                              | 34.40       | 388             | 446        | Dog            | 51            | 66           | Y <sup>23</sup>        | Poor                      |
| Busselton-Margaret River 71                     | 35.56       | 281             | 361        | Dog/Lemon      | 51            | 66           | N                      | Poor                      |
| Picton-Pinjarra-Busselton/Kemerton 81 - PIC end | 12.7        | 639             | 737        | Lemon/Bear     | 63            | 132          | Y                      | Poor                      |
| Picton-Pinjarra-Busselton/Kemerton 81 - BSN end | 85.65       | 732             | 885        | 37/3.50 AAAC   | 19            | 132          | Y                      | Good                      |
| Picton-Pinjarra-Busselton/Kemerton 81 - PNJ end | 85.04       | 732             | 845        | Bear/Lime      | 63            | 132          | Y                      | Poor                      |

## 2.5 Transmission Lines – Structures

The expected mean replacement life of transmission line wood pole and steel structures are 62 years and 55 years<sup>24</sup>, respectively. The key transmission line conductor and structure data for the transmission line circuits between Picton and Busselton have been profiled in relation to their distribution along the line circuits within Appendix B.

Table 2.5 below provides a summary of key information relating to the type and age distribution of the structures within the Picton South line circuits.

<sup>22</sup> Picton-Capel/Westralian Sands 71 has been constructed to 132kV standard, including most post insulators and pole top hardware equipment

<sup>23</sup> Approximately 70% of the Capel -Busselton 71 circuit has been constructed to 132kV standard however, the conductor is 'Dog' type which is not suitable for 132kV energisation, due to corona discharge issues.

<sup>24</sup> Engineering assessment has been applied in determining the steel pole structure mean replacement life. Unlike wood pole structures, it is not possible to derive a reliable and rational asset survival life from the historical low replacement volumes associated with steel pole structures.



The key transmission line conductor and structure data for the transmission line circuits between Picton and Busselton have been profiled in relation to their distribution along the line circuits within Appendix B.

**Table 2.5: Picton South transmission line circuits – Structures**

| Transmission Line                               | # of structures | Length (km) | Primary structure material type | Age Distribution (%) |           |           |                   | Ave Age (yrs) |
|---|-----------------|-------------|---------------------------------|----------------------|-----------|-----------|-------------------|---------------|
|   |                 |             |                                 | <30 yrs              | 30-40 yrs | 40-50 yrs | >50 yrs           |               |
| Picton-Capel/Westralian Sands 71                | 181             | 31.89       | Steel                           | 2%                   | 98%       | 0%        | 0%                | 31.5          |
| Picton-Capel 72                                 | 221             | 34.79       | Wood                            | 0%                   | 26%       | 74%       | 0%                | 35.3          |
| Capel-Busselton 71                              | 180             | 33.05       | Wood                            | 28%                  | 0%        | 0%        | 72% <sup>25</sup> | 36.3          |
| Capel-Busselton 72                              | 205             | 34.40       | Wood                            | 70%                  | 0%        | 0%        | 30% <sup>9</sup>  | 29.4          |
| Busselton-Margaret River 71                     | 197             | 35.56       | Wood                            | 24%                  | 5%        | 25%       | 46%               | 40.5          |
| Picton-Pinjarra-Busselton/Kemerton 81 - PIC end | 69              | 12.7        | Wood                            | 45%                  | 1%        | 36%       | 17%               | 34.1          |
| Picton-Pinjarra-Busselton/Kemerton 81 - BSN end | 309             | 85.65       | Steel                           | 100%                 | 0%        | 0%        | 0%                | 15.9          |
| Picton-Pinjarra-Busselton/Kemerton 81 - PNJ end | 380             | 85.04       | Wood                            | 53%                  | 29%       | 0%        | 17%               | 27.0          |

<sup>25</sup> A significant portion of the structures beyond 50 years old fall on the Capel-Busselton 71 & 72 line circuits fall within the first 12-15km from the Busselton end. See Appendix J for further detail.

## 3. Planning Drivers

### 3.1 Planning Criteria

Western Power has security, reliability and quality of supply obligations defined in the Technical Rules (December 2016 – Rev 3) and identified in Chapter 12 of the Electricity Networks Access Code (2004). The Technical Rules establish the planning criteria that Western Power applies across the SWIS. Western Power owned substations in the Picton South region are planned under the N-1 criterion. Refer to section 25: Appendix N for further detail on the Technical Rules requirements

### 3.2 N-1 Criterion – Steady State Network Performance

Relating to the steady state network performance requirements prescribed under Table 2.2 of the Technical Rules, several existing (post-tap) low voltage and (pre-tap) excessive voltage step issues arise under high system demand conditions, following the loss of the single 132kV supply into Busselton<sup>26</sup>.

Following the loss of the single 132kV supply into Busselton, the network is currently limited when:

- demand in the region exceeds 118MW (but remains below 128MW), the region's 66kV network is susceptible to unacceptable (and non-compliant) low voltages and excessive voltage step that can result in damage to Western Power and customer equipment;
- demand in the region exceeds or is forecast to exceed 128MW<sup>27</sup>, the 66kV network is susceptible to a 'blackout' scenario, resulting in the initial loss of supply of up to 46,000 (of which 81 are on life support) customers supplied within the Picton South region.

As illustrated in Figure 7 in section 1.5, the Picton South peak demand has historically been well above 118MW and close to or above the 128MW threshold on numerous occasions. With slight growth forecast over the long term, the likelihood of voltage related issues is increasing. These corresponding Busselton and Margaret River aggregate demand at these limits are 48MW and 52MW, respectively.

In addition, the Busselton 22kV distribution network is now increasingly at risk of sustained overvoltages during daytime periods, due to a combination of lower overall demand, higher efficiency residential equipment and increasing connection of rooftop solar that is reducing daytime demand. During these minimum daytime conditions, the zone substation transformer tap changers are reaching their minimum tap positions, resulting in a loss of voltage control and inability to reduce voltages, putting the network at risk of sustained overvoltages for the next contingency (i.e. load rejection scenario).

### 3.3 Short Term Voltage Stability

Western Power's Transmission Planning Guidelines require all transmission and distribution buses to recover to 0.9pu of nominal voltage without employing under voltage load shedding, following the worst case credible contingency. Transient overvoltage requirements must also be satisfied in accordance with Technical Rules Clause 2.2.10. Despite the Picton to Busselton line circuits having sufficient thermal capacity, the relative high impedance 66kV network has already exceeded its voltage capacity, resulting in voltage stability limitations in the area. Sensitivity studies performed over a range of generation dispatch

<sup>26</sup> Low voltage and excessive voltage step issues arise over multiple contingencies, with the worst case being the loss for the single 132kV supply into Busselton.

<sup>27</sup> By 2021, both Picton T3 and T5 substation transformers will be replaced and upgraded to 132kV. Although these works result in the entire Picton demand being supplied via the 132kV network, it only increases the limits to 122MW and 131MW respectively, as demand changes at Busselton and Margaret River are significantly more sensitive than at Picton

conditions, identified that at a power transfer of 48MW into Busselton and Margaret River, the voltages at Busselton and Margaret River adequately recover.

Historically, the aggregate Busselton and Margaret River demand levels have been much higher than the stability limit<sup>28</sup>. At these levels, the network is unsecure and susceptible to sustained low voltages that can lead to equipment damage, further outages and in the worst-case, a ‘blackout’ scenario to the region. Furthermore, this risk is anticipated to worsen with peak demand growth forecast in the Picton South region over the long term.

### 3.4 Long Term Voltage Stability

Western Power’s Transmission Planning Guidelines require that all parts of the network must demonstrate a positive reactive power margin prior to the operation of tap changing, following the worst-case credible contingency. The reactive power reserve at a point in the network is the amount of additional reactive power that could be supplied from that point, whilst maintaining voltages within the prescribed limits specified in clause 2.2.2 (a) of the Technical Rules.

The existing reactive reserve margin was calculated at Busselton 66kV busbar, which is most sensitive to demand changes. The results of the long-term stability studies identified an existing reactive reserve deficit of 14.5MVAR at the Busselton 66kV busbar, following the loss of the 132kV supply line into Busselton. The corresponding level of demand at Busselton and Margaret River that will result in adequate long-term voltage stability is 51MW.

### 3.5 Maximum Supportable Demand

The maximum supportable demand is defined as the maximum level of power transfer (or demand) that achieves adequate network performance relating to thermal, steady state voltages, voltage step and voltage stability. Clause 2.3.8 of the Technical Rules states that the maximum supportable demand is limited to 95% of the stability limit.

Based on the above definition, the maximum power transfer into Busselton and Margaret River is the level of demand that achieves adequate steady state and transient network performance is 48MW, resulting in a maximum supportable demand of 95% of this power transfer, or 46MW.

Based on the historical and forecast Busselton and Margaret River peak demand levels shown in Table 3.1 and Table 3.2, the existing maximum supportable demand is inadequate.

Network augmentation works are required to increase the maximum supportable demand to meet the forecast peak demand at Busselton and Margaret River to approximately 68MW in 2028 and 73MW in 2042.

**Table 3.1: Busselton and Margaret River historical peak demand (2013–2018) – PoE10% System peak**

| Peak Demand                | 2013 | 2014 | 2015 | 2016 | 2017 | 2018 |
|----------------------------|------|------|------|------|------|------|
| Busselton & Margaret River | 55.3 | 48.1 | 57.5 | 61.5 | 55.8 | 58.4 |

**Table 3.2: Busselton and Margaret River forecast peak demand (2019-2042)– PoE10% System peak**

| Peak Demand                | 2019 | 2020 | 2021 | 2022 | 2023 | 2024 | 2025 | 2026 | 2027 | 2028 | 2042 |
|----------------------------|------|------|------|------|------|------|------|------|------|------|------|
| Busselton & Margaret River | 60.9 | 62.7 | 63.5 | 64.5 | 65.3 | 66.0 | 66.7 | 67.2 | 67.8 | 68.2 | 72.6 |

<sup>28</sup> Busselton and Margaret River demand reached 56MW during 2017 system peak conditions

## 4. Committed Projects

### 4.1 Present Projects

Table 4.1 below summarises the projects within the Bunbury load area that are committed and on track to be completed by the end of the Access Arrangement 4 period (2017-2022). These projects have been considered in the development of the Picton South capacity expansion.

**Table 4.1: Bunbury load area – Committed projects and anticipated benefits**

| Project   | Benefit/s  | Project Phase | By when        |
|---|--|---------------|----------------|
| Install a 132/22kV transformer to replace 66/22kV T3 at Picton substation | Address degraded asset condition.  | Execution     | Summer 2020/21 |
| Install a 132/22kV transformer to replace 66/22kV T5 at Picton substation | Address failed asset.  | Planning      | Winter 2022    |
| Install a 132/22kV transformer at Capel substation <sup>29</sup>          | Accommodate increasing demand in the area; address degraded asset condition. | Execution     | Autumn 2021    |
| Decommission Coolup substation  | Address degraded asset condition; consolidation of 66kV network assets       | Planning      | Summer 2020/21 |

### 4.2 Completed Projects

**Table 4.2: Bunbury load area – Recently completed projects**

| Project   | Benefit/s  | Completed   |
|---|--|-------------|
| Replacement of two 66/22kV transformers at Margaret River substation with a larger 33MVA and 132-66kV voltage reconfigurable unit | Address degraded asset condition; accommodate increasing demand in the area.   | Autumn 2016 |
| Partial conversion of Busselton 66kV substation to 132kV  | Accommodate increasing demand in the area; address degraded asset condition  | Autumn 2017 |
| Install switches on the Pinjarra-Kemerton-Picton-Busselton 132kV line   | Address reliability issues during bushfires for the four ended Pinjarra-Kemerton-Picton-Busselton 132kV line <sup>30</sup> | Autumn 2017 |

<sup>29</sup> Capel substation will operate with 3 transformers for a period until an additional transformer is commissioned at Capel to allow the existing two transformers to be retired. This approach maintains N-1 compliance at Capel substation.

<sup>30</sup> In 2016, Western Power improved the reliability of this (183km) line through the installation of a controllable switch in the Wokalup locality. This switch provides bushfire risk benefits during bushfire season by segmenting the 132kV line north of Wokalup up to Pinjarra and reducing the line exposure that can lead to voltage issues in the Picton South network by 85km (or 46%). As the segmentation of the network reduces the system security, the open status of the switch is not recommended as a permanent arrangement.

## 5. Options Considered

### 5.1 Network Options

Consistent with the Bunbury load area long term staging report, a number of investment pathways have been developed to address the range of network issues, based on the following two broad investment themes

- Conversion of the Picton South network to operate at 132kV; and
- Retention of the existing 66kV network topology and asset base.

Furthermore, several strategic network options have been developed, with the following considerations:

- Western Power 66kV asset rationalisation strategy;
- Technical feasibility;
- Compliance with the Technical Rules;
- Western Power standards;
- Financial feasibility (NPC and lowest capital cost); and
- Risk profile and mitigation.

Western Power has completed detailed planning studies in considering feasible options to mitigate all of the identified network limitations within the Picton South network over the medium to long term, as discussed in section 3. These studies include steady state and dynamic load flow analysis as well as other technical assessments to determine the capacity of various options to adequately reduce the identified network risks.

### 5.2 Non-Network Options

Non-network options include options that diverge from traditional investment paths to meet project drivers. Western Power has explored Network Control Services<sup>31</sup> (NCS) in the Picton South region to determine the feasibility of two NCS sub-categories:

- **Demand Side Management (DSM)** – DSM considers contracting an aggregated set of network loads that can be curtailed operationally to meet a network objective (voltage or capacity constraint); and
- **Generation** – NCS generation involves contracting a generator (or set of generators) to provide dispatchable support services in an area where such support is operationally feasible.

Both NCS sub-categories involve a competitive commercial tendering process and would be required to respond on a pre-contingent basis to manage network compliance and capacity shortfall. NCS contracts are administered through appropriate contractual mechanisms that involve a fixed and variable allocation of costs, with relevant availability / dispatchability obligations.

Procurement of an NCS contract is expected to address the existing voltage capacity limitations and support higher levels of maximum supportable demand however, it will not address any asset condition issues.

Due to the availability of accurate costings, Western Power has assumed the procurement of generation under an NCS contract. However, Demand Side Management could equally be used to deliver similar outcomes.

---

<sup>31</sup> Network Control Services are services provided by generation and/or Demand Side Management that can be substituted for an upgrade to the transmission and distribution network.

An option has been developed that considers asset replacement works together with the procurement of generation under an NCS contract. Although grid scale battery technology costs are rapidly falling, they are still higher than other mature technologies such as gas turbine generation. As a result, gas turbine generation have been considered under the procurement of NCS generation throughout this Options Paper.

Western Power has investigated a number of additional network and non-network options that were either not viable or cost prohibitive, and as a result have been discounted. Refer to Appendix F for further detail.

### 5.3 Key Assumptions

The following key assumptions have been used in the preparation of this Options Paper:

- Western Power’s 25-year 2017 peak demand forecasts have been utilised in the assessment of investment options. Minimum demand conditions have also been considered.
- Technical analysis utilised DIgSILENT PowerFactory for power system studies, including load flow analysis, fault level analysis and transient response analysis.
- Financial analysis utilised Western Power’s Investment Evaluation Model (IEM), a calculation software utilised to assess whether the New Facilities Investment Test (NFIT) criteria outlined in the Electricity Networks Access Code 2004 have been met. Parameter inputs to the IEM are based on those agreed within Access Arrangement 4, and include:
  - Weighted average cost of capital (WACC) of 6.39% - this is the discount rate (pre-tax nominal);
  - Annual escalation rates for various components:
    - Labour – 3.00%
    - Materials, equipment and plant – 2.20%
    - Inflation – 2.20%
  - Base year is set to 2018/19;
  - The annualised cost of operating new assets (OPEX) is calculated at 0.3% of capital expenditure (CAPEX), where applicable; and
  - Cost analysis considers a +/- 20% sensitivity band on the CAPEX, in addition to the base cost, across all investment options.
- All development strategies presented within the Options Paper assume that the committed projects detailed in Table 4.1 are completed without changes to scope and timing. Subsequently, these works are common to all development strategies and therefore excluded from the scope and costings.
- Consistent with Western Power’s asset strategies, the expected mean replacement life for following primary plant assets are shown below:
  - Power transformers: 55 years
  - Circuit breakers: Oil – 41 years, SF6 – 33 years
  - Disconnectors: 53 years

- Current & voltage transformers – 40 years
- Transmission structures – wood – 62 years, steel – 55 years
- Transmission overhead conductors – 80 years
- Western Power replaces assets using a risk-based approach which considers condition<sup>32</sup>, likelihood of failure and consequence of failure. Where forecast condition information is not available, age has been used to forecast replacement timings.
- A 50-year evaluation period has been used for the options assessment, with the peak demand forecasts beyond 25 years assumed to have no growth. The capital and operating expenditure associated with the 66kV substation and transmission line assets from Picton to Busselton substations has been included to provide equivalency in comparing options over the long term<sup>33</sup>. For further detail on the asset replacement works considered in the costings, refer to Appendix C and Appendix D.
- Development strategies 1-3 propose the early replacement of the Picton T4 transformer due to operational risks that arise once both Picton terminal transformers are out of service. During peak conditions and following a transformer contingency, the temporary paralleling of the Picton 22kV busbar to energise the 66/22kV transformer will result in the remaining 132/22kV transformer experiencing a short-term overload of 148% (125% when Capel is upgraded to 132kV) as it partially supplies the 66kV network in addition to the existing Picton load. Depending on its condition at the time, Picton T4 may be used as a strategic spare.
- All terminal transformer replacements proposed under each of the development strategies utilise the standard 100MVA terminal transformers. Although this capacity is above future anticipated 66kV Picton South demand, using standard sized transformers represents lower total costs by maintaining lower volumes of strategic spares. Furthermore, a failure of the Picton terminal transformers prior to the load being resupplied at 132kV would require a 100MVA capacity transformer to adequately meet the peak demand.
- Westralian Sands Substation supply arrangement is maintained at 66kV under all development strategies, providing equivalency in comparing options. In addition to no identified changes in the customer's supply requirements, an assessment has been completed to demonstrate that a 66kV supply arrangement is the optimal network supply arrangement over the medium to long term<sup>34</sup>.

## 5.4 Development Strategy 1: Picton South 132kV conversion – Accelerated conversion

The first development strategy primarily involves upgrading the supplies to the Picton South region to 132kV voltage to eliminate the reliance on the Picton terminal transformers in providing supply and maintaining system security to the region.

Under this pathway, the existing 66kV supplies between Picton and Capel will be converted to 132kV via the construction of a new 33km 132kV rated double circuit line (with one circuit initially operated at 66kV) between Capel and Busselton. Due to the uncertainty around the need and timing of a third 132kV supply line into Busselton, none of the development strategies present the complete long-term network development view. Instead, a 132kV double circuit between Capel and Busselton aims to address the

<sup>32</sup> See Table A.1 and Appendix A.

<sup>33</sup> Asset replacement expenditure between Busselton and Margaret River have been excluded as the replacement costs are expected to be common under all options.

<sup>34</sup> Refer to Appendix I for further detail.

existing and emerging transmission line asset condition issues, while providing an accelerated pathway towards the long-term network development view, which is more consistent with the current long term peak demand forecasts.

In addition to a series of substation transformer asset replacement works, additional reactive support devices are proposed to address existing voltage capacity limitations, providing increased maximum supportable demand to accommodate future growth in the area beyond the forecast peak demand.

The development strategy comprises of a number of individual investments. The scope and associated costings of the individual investments proposed under Development Strategy 1 are detailed in Table 5.1.

**Table 5.1: Individual investments under Development Strategy 1 - Scope and cost**

| Year Required | Substation       | Proposed Augmentation  | Key Driver  | Real Cost (\$M) <sup>35</sup> |
|---------------|------------------|--|---|-------------------------------|
| 2022          | Picton / Capel   | Uprate Picton-Capel/Westralian Sands 71 (future Picton-Capel 81) transmission line pole top hardware and earth wires to 132kV (initially energised at 66kV).   | Address asset condition & system security issues within the Picton South region <sup>36</sup> . | \$5.9                         |
|               | Westralian Sands | Transfer Westralian Sands 66kV tee-line from Picton-Capel/Westralian Sands 71 to Picton-Capel 72 transmission line via the construction of a new 3km 132kV rated (energised at 66kV) wood pole single circuit with 'Lemon' conductors. |   |                               |
| 2023          | Busselton        | Extension of the 132kV busbar, including a new 132kV disconnecter to facilitate the connection of a new terminal transformer.  | Address asset condition & system security issues within the Picton South region.                | \$14.0                        |
|               |                  | Installation of a new 132kV Tx bay and 100MVA 132/66/22kV terminal transformer.  |   |                               |
| 2024          | Busselton        | Installation of (+/-) 12MVAR dynamic reactive support devices (i.e. STATCOM) and associated 66kV step-up transformer.  | Address voltage related N-1 non-compliances.  | \$15.4                        |
|               |                  | Installation of 10MVAR 22kV capacitor banks and associated equipment connected to the tertiary winding of the new terminal transformer.  | Increase Picton South maximum supportable demand.   |                               |
| 2025          | Busselton        | Installation of a new 132kV transformer bay and a single 132/22 33MVA transformer to replace 3 x 66/22kV smaller transformers (T1, T2 & T3).   | Address asset condition issues.   | \$7.9                         |

<sup>35</sup> Real Cost – Total capital cost, including risk, labour on costs and locality factor.

<sup>36</sup> Under a double Picton terminal transformer contingency, resupplying Westralian Sands onto the adjacent 66kV line circuit and uprating the Picton-Capel/Westralian 71 circuit allows Capel Substation to be resupplied at 132kV with minimum works being required to restore supply and avoid significant load shedding. Over the long term, the conversion of the supplies between Picton and Busselton will remove the reliance of the Picton terminal transformers.



| Year Required   | Substation  | Proposed Augmentation  | Key Driver  | Real Cost (\$M) <sup>35</sup> |
|---|---|--|---|-------------------------------|
|   |   | Decommission and remove the 3 x 66/22kV transformers.  |   |                               |
| 2027  | Busselton   | Construction of a new 33km 132kV rated steel pole double circuit between Busselton and Capel substations. Operate one circuit at 66kV as the new Capel-Busselton 71 circuit.<br>Minor distribution protection upgrade works. | Address asset condition & system security issues within the Picton South region.<br>Increase Picton South maximum supportable demand. | \$63.8                        |
|   | Capel   | Installation of a new 132/22kV 33MVA transformer.  | Address asset condition;<br>Energise network at 132kV.  | \$8.8                         |
|   |   | Decommission and remove the existing 66/22kV transformers, T1 and T3.  |   |                               |
|   |   | Re-terminate the HV winding of the reconfigurable Capel transformer, T5, to the 132kV winding and energise the Capel substation to 132kV voltage.  |   |                               |
| Picton  | Replace the remaining 66/22kV transformer (T4) at Picton with a new 132/22kV 33MVA transformer. | Address asset condition issues.  | \$6.8   |                               |
| 2028  | Busselton/Capel   | Decommission and remove 33km of the Capel-Busselton 71 circuit and 35km of the Capel-Busselton 72 circuit.   | Address asset condition.  | \$16.5                        |
|   | Picton/Capel  | Decommission and remove 26km of the Picton-Capel 72 circuit <sup>37</sup> .  | Address asset condition.  | \$3.6                         |
|   | Picton  | Decommission and remove terminal transformers and Picton 66kV busbar assets.   | Address asset conditions issues.  | \$0.8                         |
| <b>Total NPC (including risk and escalation) - \$156.1M</b> |   |  |   |                               |

<sup>37</sup> Due to the difficulty in obtaining line corridors and easements, Western Power expects to maintain the corridor and easements for the section of lines decommissioned for the possibility that a third 132kV supply into Busselton is required in the future.

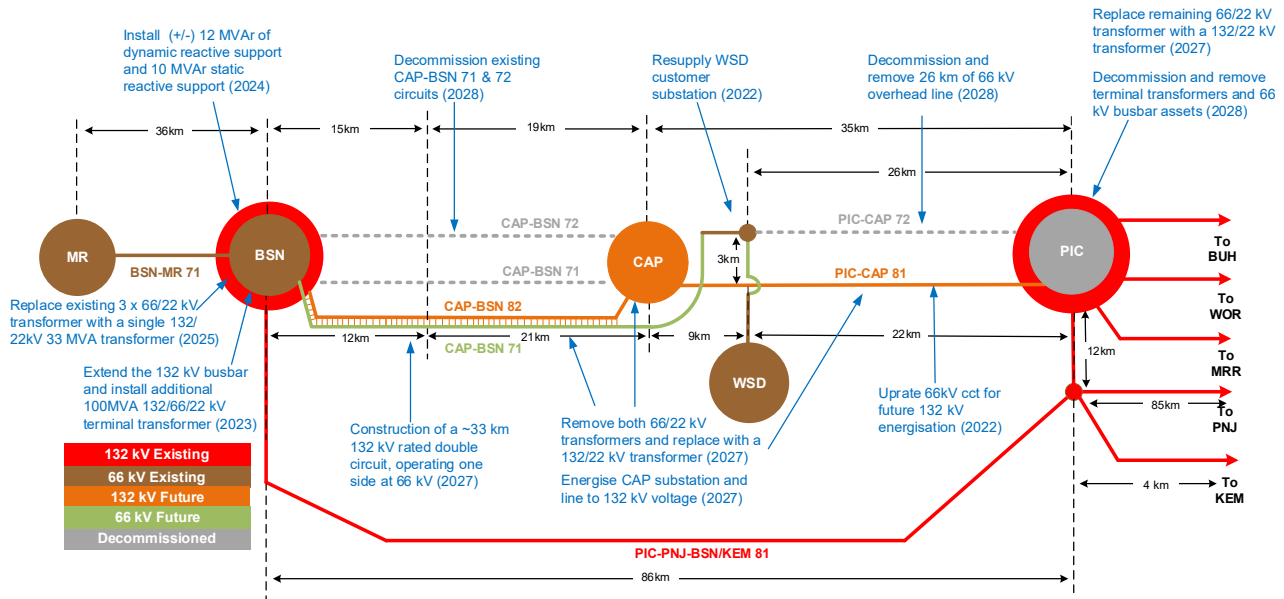

Figure 9: Development Strategy 1 – Scope overview

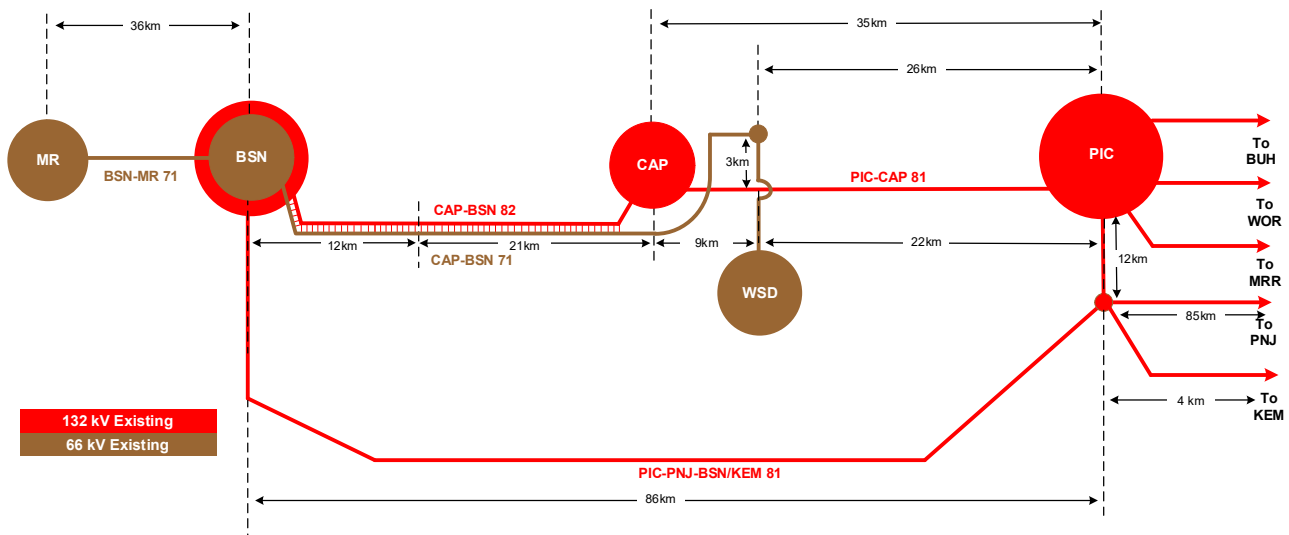

Figure 10: Development Strategy 1 – Final network configuration

## 5.5 Development Strategy 2: Picton South 132kV conversion – Staged 132kV conversion - Busselton Terminal Transformer

The second development strategy is similar to Development Strategy 1 but proposes a staged approach to upgrading the supplies to 132kV voltage within the Picton South region.

Under this development strategy, the existing 66kV supplies between Picton and Capel will be converted to 132kV, with the network development between Capel and Busselton involving the construction of a new 12km 132kV rated double circuit line and reconductoring, rather than an accelerated conversion of both supplies between Capel and Busselton to 132kV<sup>38</sup>.

<sup>38</sup> Although the long-term network development view indicates a requirement for three 132kV supplies into Busselton, declining peak demand forecasts has created uncertainty on the timing of this network development view. Section 23 provides a detailed assessment to demonstrate

The development strategy comprises of a number of individual investments. The scope and associated costings of the individual investments proposed under Development Strategy 2 are detailed in Table 5.2.

**Table 5.2: Individual investments under Development Strategy 2 - Scope and cost**

| Year Required | Substation        | Proposed Augmentation  | Key Driver  | Real Cost (\$M) <sup>39</sup> |
|---------------|-------------------|--|---|-------------------------------|
| 2022          | Picton / Capel    | Uprate Picton-Capel/Westralian Sands 71 (future Picton-Capel 81) transmission line pole top hardware and earth wires to 132kV (initially energised at 66kV).   | Address asset condition & system security issues within the Picton South region <sup>35</sup> . | \$5.9                         |
|               | Westralian Sands  | Transfer Westralian Sands 66kV tee-line from Picton-Capel/Westralian Sands 71 to Picton-Capel 72 transmission line via the construction of a new 3km 132kV rated (energised at 66kV) wood pole single circuit with 'Lemon' conductors. |   |                               |
| 2023          | Busselton         | Extension of the 132kV busbar, including a new 132kV disconnecter to facilitate the connection of a new terminal transformer.  | Address asset condition & system security issues within the Picton South region.                | \$14.0                        |
|               |                   | Installation of a new 132kV Tx bay and 100MVA 132/66/22kV terminal transformer.  |   |                               |
| 2024          | Busselton         | Installation of (+/-) 12MVar dynamic reactive support devices (i.e. STATCOM) and associated 66kV step-up transformer.  | Address voltage related N-1 non-compliances.  | \$15.4                        |
|               |                   | Installation of 10MVar 22kV capacitor banks and associated equipment connected to the tertiary winding of the new terminal transformer.  | Increase Picton South maximum supportable demand.   |                               |
| 2025          | Busselton         | Installation of a new 132kV transformer bay and a single 132/22 33MVA transformer to replace 3 x 66/22kV smaller transformers (T1, T2 & T3).   | Address asset condition issues.   | \$7.9                         |
|               |                   | Decommission and remove the 3 x 66/22kV transformers.  |   |                               |
| 2027          | Busselton / Capel | Reconductor the first 19km of the existing Capel-Busselton 71 line circuit with 'Lemon' conductors.  | Address asset condition & system security issues within the Picton South region.                | \$44.9                        |
|               |                   | Construction of a new 12km 132kV rated D-circuit section from the Busselton substation. Re-terminate the Capel-Busselton 71 and 72 circuit to this new section.  |   |                               |
|               |                   | Minor distribution protection upgrade works.   |   |                               |

that a 12km 132kV double circuit rebuild of the Capel to Busselton circuits end represents a more cost-effective way to address the asset condition issues relating to the wood poles in the area, irrespective of the future capacity requirements into Busselton.

<sup>39</sup> Total capital cost - Including risk and labour on costs

| Year Required   | Substation | Proposed Augmentation   | Key Driver   | Real Cost (\$M) <sup>39</sup> |
|---|------------|---|--|-------------------------------|
|   |            | Decommission and remove 12km of the Capel-Busselton 71 circuit and 15km of the Capel-Busselton 72 circuit from the Busselton substation end.      | Increase Picton South maximum supportable demand.          |                               |
|   | Capel      | Installation of a new 132/22kV 33MVA transformer.   | Address asset condition issues; Energise network at 132kV. | \$8.8                         |
|   |            | Decommission and remove the existing 66/22kV transformers, T1 and T3.   |  |                               |
|   |            | Re-terminate the HV winding of the reconfigurable Capel transformer, T5, to the 132kV winding and energise the Capel substation to 132kV voltage. |  |                               |
|   | Picton     | Replace the remaining 66/22kV transformer (T4) at Picton with a new 132/22kV 33MVA transformer.   | Address asset condition issues.                            | \$6.8                         |
| 2028  | Picton     | Decommission and remove 26km of the Picton-Capel 72 circuit.  | Address asset condition.                                   | \$3.6                         |
|   |            | Decommission and remove terminal transformers and Picton 66kV busbar assets.  | Address asset conditions issues.                           | \$0.8                         |
| <b>Total NPC (including risk and escalation) - \$143.6M</b> |            |   |  |                               |

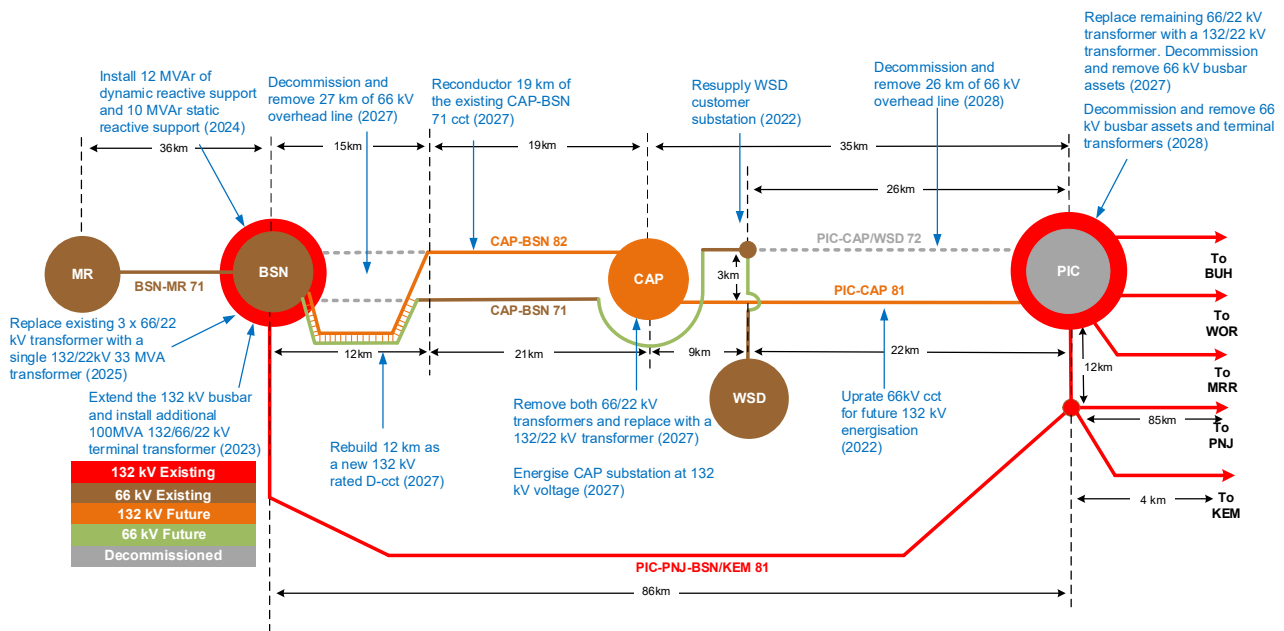

Figure 11 Development Strategy 2 – Scope overview

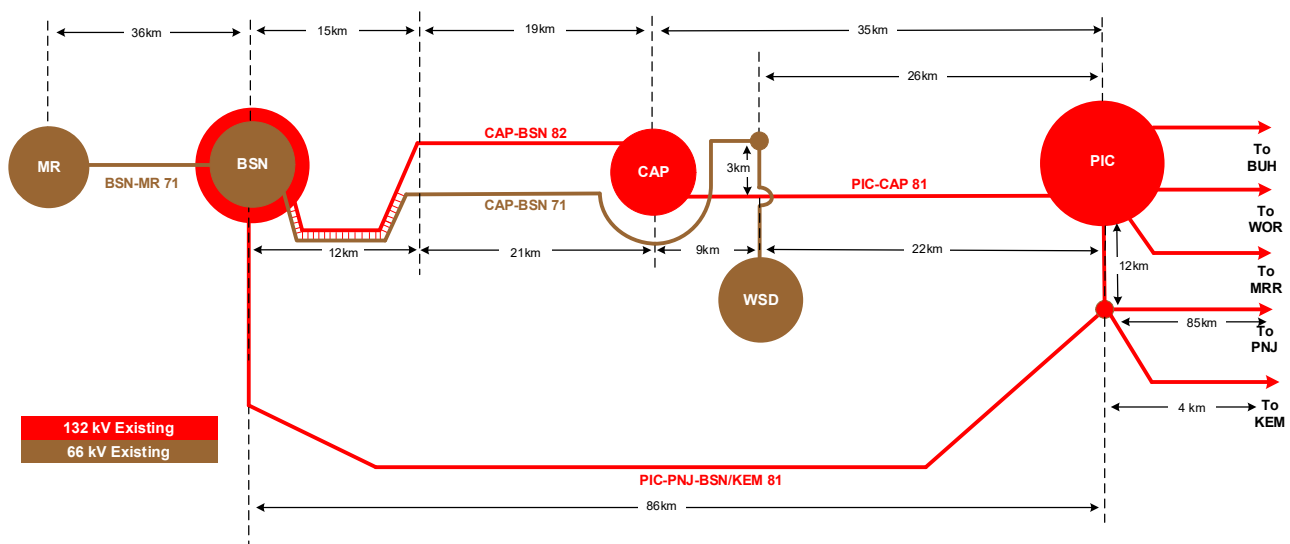

Figure 12 Development Strategy 2 – Final network configuration

## 5.6 Development Strategy 3: Picton South 132kV conversion – Staged 132kV conversion - Picton Terminal Transformer

The third development strategy also involves a staged 132kV conversion of the existing 66kV supplies between Picton and Busselton and is very similar to investments covered under Development Strategy 2, with variations around the location of the new terminal transformer installation and size of reactive support devices required.

Under this option, a new 100MVA 132/66/22kV terminal transformer is proposed at Picton substation, rather than at Busselton substation. The installation of the terminal transformer at Picton results in slightly higher levels of reactive support required at Busselton to achieve similar levels of maximum supportable demand and diminished opportunity to decommission and remove the Picton 66kV substation assets and a portion of the existing Picton-Capel 72 line assets.

The development strategy comprises of a number of individual investments. The scope and associated costings of the individual investments proposed under Development Strategy 3 are detailed in Table 5.3.

**Table 5.3: Individual investments under Development Strategy 3 - Scope and Cost**

| Year Required | Substation        | Proposed Augmentation  | Key Driver  | Real Cost (\$M) <sup>40</sup> |
|---------------|-------------------|--|---|-------------------------------|
| 2022          | Picton / Capel    | Uprate Picton-Capel/Westralian Sands 71 (future Picton-Capel 81) transmission line earth wires to support future energisation at 132kV.  | Address asset condition & system security issues within the Picton South region <sup>35</sup> .                   | \$5.9                         |
|               | Westralian Sands  | Transfer Westralian Sands 66kV tee-line from Picton-Capel/Westralian Sands 71 to Picton-Capel 72 transmission line via the construction of a new 3km 132kV rated (energised at 66kV) wood pole single circuit with 'Lemon' conductors. |   |                               |
| 2023          | Picton            | Extension of the 132kV busbar, including a new 132kV bus coupler to facilitate the connection of a new terminal transformer.   | Address asset condition & system security issues within the Picton South region.                                  | \$14.8                        |
|               |                   | Installation of a new 132kV Tx bay and 100MVA132/66/22kV terminal transformer.   |   |                               |
| 2024          | Busselton         | Installation of (+/-)16MVAR dynamic reactive support devices (i.e. STATCOM) and associated 66kV step-up transformer.   | Address voltage related N-1 non-compliances.  | \$15.9                        |
|               |                   | Installation of 15MVAR 66kV capacitor banks and associated equipment connected to the tertiary winding of the new terminal transformer.  | Increase Picton South maximum supportable demand.   |                               |
| 2025          | Busselton         | Installation of a new 132kV transformer bay and a single 132/22 33MVA transformer to replace 3 x 66/22kV smaller transformers (T1, T2 & T3).   | Address asset condition issues.   | \$7.9                         |
|               |                   | Decommission and remove the 3 x 66/22kV transformers.  |   |                               |
| 2027          | Busselton / Capel | Reconductor the first 19km of the existing Capel-Busselton 71 line circuit with 'Lemon' conductors.  | Address asset condition & system security issues within the Picton South region.<br>Increase Picton South maximum | \$44.9                        |
|               |                   | Construction of a new 12km 132kV rated D-circuit section from the Busselton substation. Re-terminate the Capel-Busselton 71 and 72 line circuit to this new section.<br>Minor distribution protection upgrade works.                   |   |                               |

<sup>40</sup> Total capital cost - Including risk and labour on costs

| Year Required   | Substation | Proposed Augmentation  | Key Driver   | Real Cost (\$M) <sup>40</sup> |
|---|------------|--|--|-------------------------------|
|   |            | Decommission and remove 12km of the Capel-Busselton 71 line circuit and 15km of the Capel-Busselton 72 line circuit from the Busselton substation end. | supportable demand.  |                               |
|   | Capel      | Installation of a new 132/22kV 33MVA transformer.  | Address asset condition issues; Energise network at 132kV.   | \$8.8                         |
|   |            | Decommission and remove the existing 66/22kV transformers, T1 and T3.  |  |                               |
|   |            | Re-terminate the HV winding of the reconfigurable Capel transformer, T5, to the 132kV winding and energise the Capel substation to 132kV voltage.      |  |                               |
| 2053  | Picton     | Replace the remaining 66/22kV transformer (T4) at Picton with a new 132/22kV 33MVA transformer.  | Address asset condition issues.                              | \$6.8                         |
|   | Busselton  | Relocate the Picton Terminal transformer to Busselton substation <sup>41</sup> .   | Increase reliability of supply to Margaret River substation. | \$8.5                         |
| 2054  | Picton     | Decommission and remove 26km of the Picton-Capel 72 circuit.   | Address asset condition.                                     | \$3.6                         |
|   |            | Decommission and remove terminal transformers and Picton 66kV busbar assets.   | Address asset conditions issues.                             | \$0.8                         |
| <b>Total NPC (including risk and escalation) - \$148.9M</b> |            |  |  |                               |

<sup>41</sup> By 2053, conductors on the Picton-Capel/Westralian Sands 72 circuit (formerly Picton-Capel 72) will reach its expected mean replacement life of 80 years, triggering the circuit to be either rebuilt at 132kV or decommissioned. As a result, the Picton terminal transformer can be relocated to Busselton substation to provide N-1 transformer supply to Margaret River.

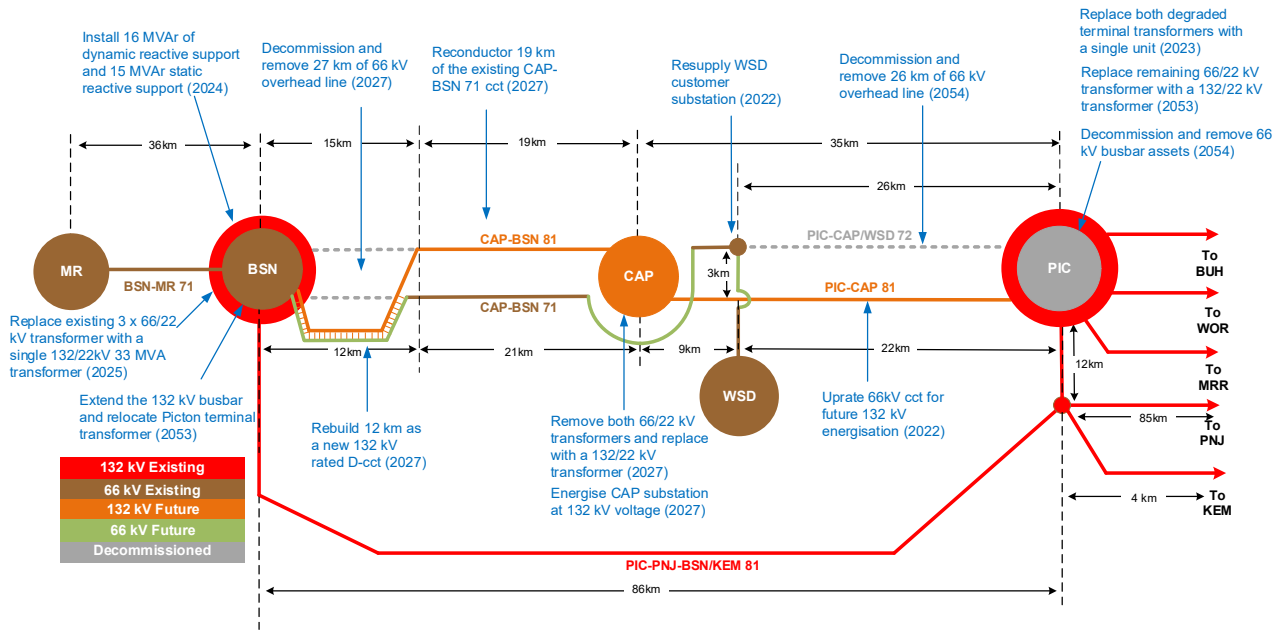

Figure 13 Development Strategy 3 - Scope overview

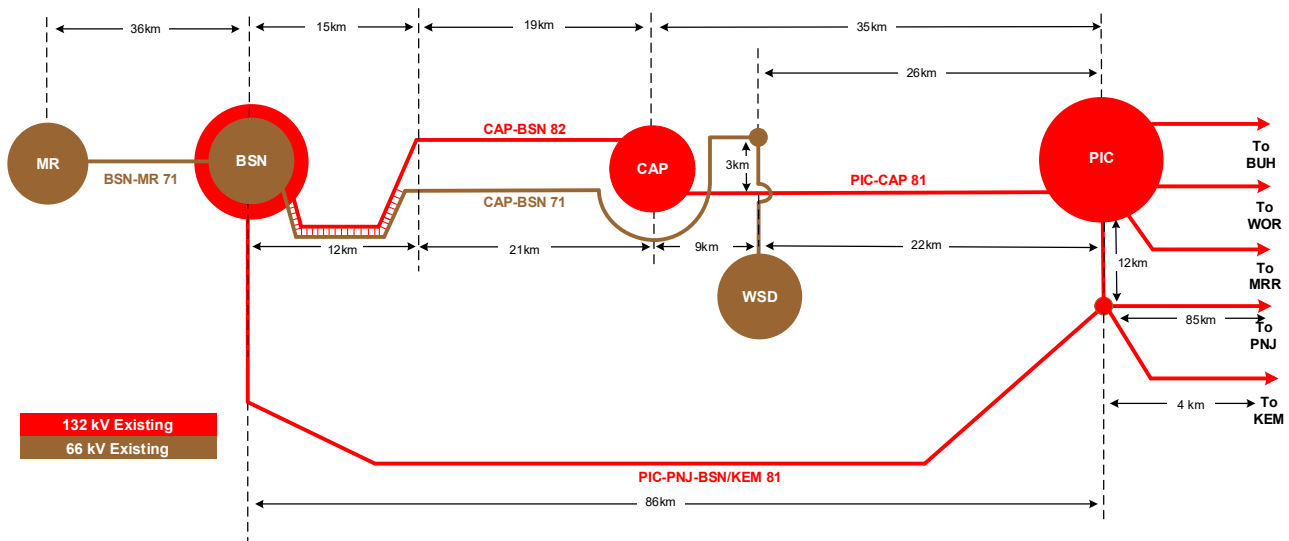

Figure 14: Development Strategy 3 – Final configuration

### 5.7 Development Strategy 4: Retain 66kV Network - Procure NCS

Development strategy 4 considers maintaining the Picton South network supply voltage at 66kV over the long term. The investment pathway addresses the existing and emerging safety, reliability of supply and system security risks associated with assets in degraded condition through like for like asset replacements, while the procurement of NCS addresses the existing voltage capacity limitations and ensures the forecast peak demand can be met over the long term.

The development strategy comprises of a number of individual investments. The scope and associated costings of the individual investments proposed under Development Strategy 4 are detailed in Table 5.4.



**Table 5.4: Individual investments under Development Strategy 4 - Scope and cost**

| Year Required  | Substation | Proposed Augmentation  | Key Driver   | Real Cost (\$M) <sup>42</sup> |
|--|------------|--|--|-------------------------------|
| 2022   | Busselton  | Procurement of 30MW <sup>43</sup> of NCS.<br>Minor distribution protection upgrade works.                                    | Address voltage capacity limitations.  | \$78.0                        |
| 2023   | Busselton  | Installation of a 5MVAr 22kV reactor bank.   | Addresses distribution over voltage issues.                                      | \$0.6                         |
|  | Picton     | Extension of the 132kV busbar, including a new 132kV bus coupler to facilitate the connection of a new terminal transformer. | Address asset condition & system security issues within the Picton South region. | \$14.8                        |
| Installation of a new 132kV transformer bay and 132/66/22kV 100MVA terminal transformer. |            |  |  |                               |
| 2025   | Picton     | Decommission and remove the both old Picton terminal transformers.   | Address asset condition & system security issues within the Picton South region. | \$11.7                        |
|  |            | Installation of a new 132kV transformer bay and 132/66/22kV 100MVA terminal transformer.                                     |  |                               |
|  | Busselton  | Replace 3 x 66/22kV smaller transformers (T1, T2 & T3) with a single larger 66/22kV 33MVA transformer.                       | Address asset condition issues.  | \$7.2                         |
| Decommission and remove the 3 x 66/22kV transformers.                                    |            |  |  |                               |
| 2027   | Capel      | Installation of a new 66/22kV 33MVA transformer.   | Address asset condition issues.  | \$8.6                         |
|  |            | Decommission and remove the existing 66/22kV transformers, T1 and T3.  |  |                               |
| 2056   | Picton     | Replace the remaining 66/22kV transformer (T4) at Picton with a new 132/22kV 33MVA transformer.                              | Address asset condition issues.  | \$6.8                         |
| <b>Total NPC (including risk and escalation) - \$178.0M</b>                              |            |  |  |                               |

<sup>42</sup> Real cost – Capital cost including risk and labour on costs

<sup>43</sup> See Appendix K for assumptions relating to the procurement of NCS

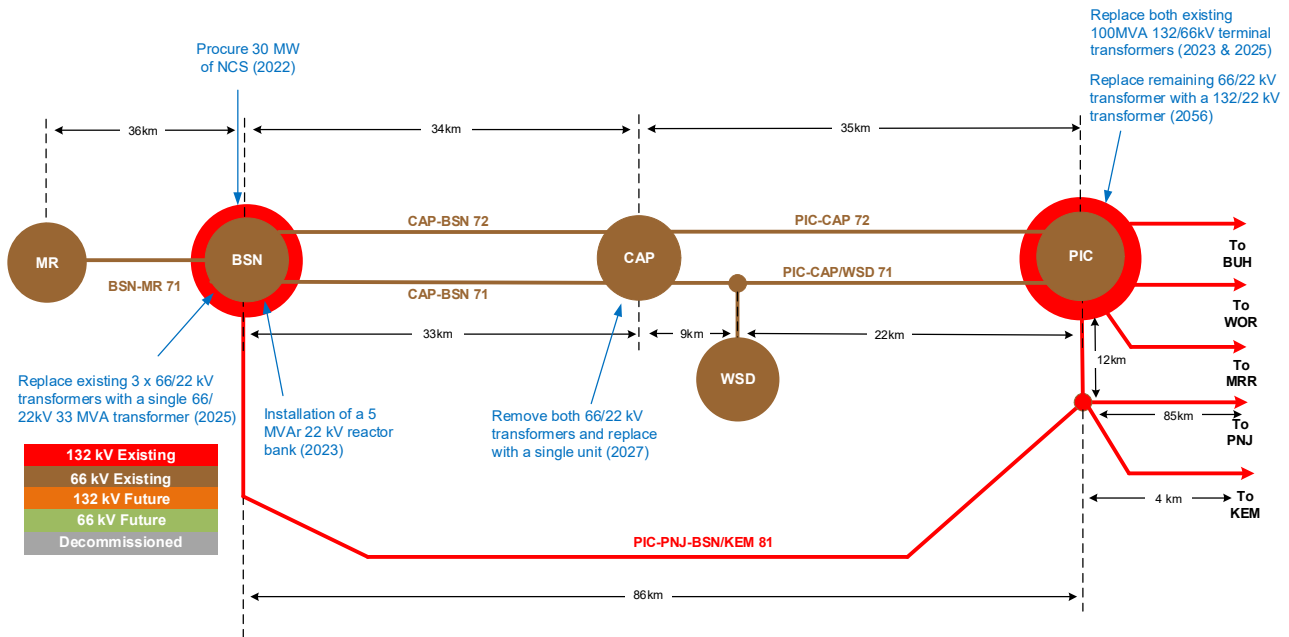

Figure 15: Development Strategy 4 - Scope overview

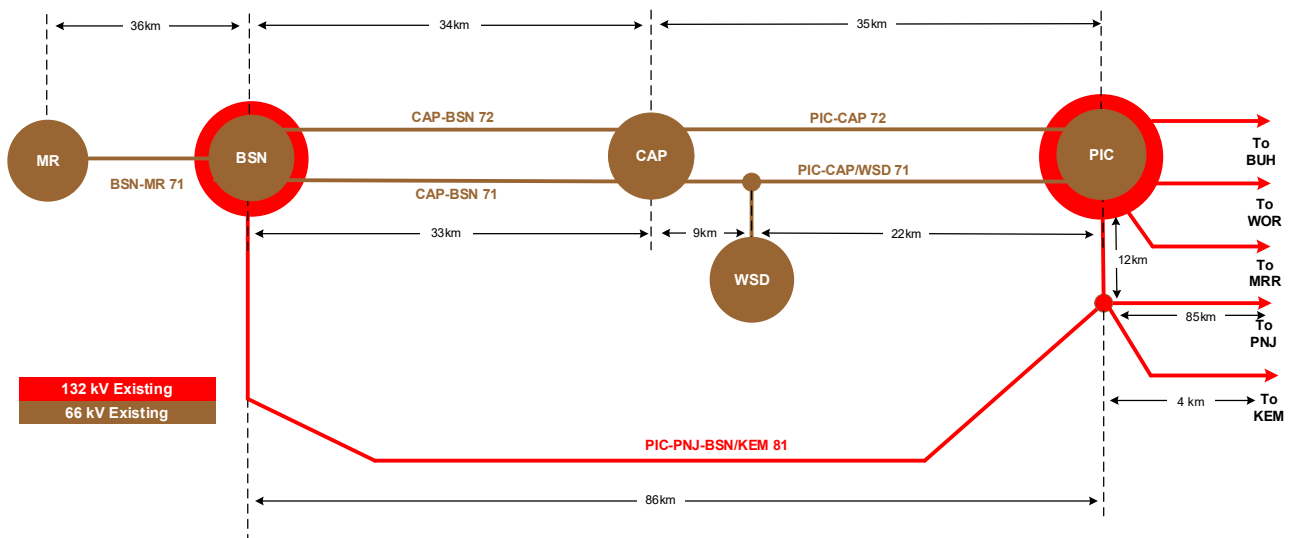

Figure 16 - Development Strategy 4 – Final network configuration

## 5.8 Development Strategy 5: Retain 66kV Network – Install Additional Reactive Support

Similar to Development Strategy 4, Development Strategy 5 also continues to maintain the Picton South network supply voltage at 66kV over the long term. Rather than procuring NCS, additional reactive support devices are proposed at Busselton Substation to address voltage capacity limitations and increase the maximum supportable demand to accommodate the forecast peak demand in the area.

The development strategy comprises of a number of individual investments. The scope and associated costings of the individual investments proposed under Development Strategy 5 are detailed in Table 5.5.

**Table 5.5: Individual investments under Development Strategy 5 - Scope and cost**

| Year Required   | Substation | Proposed Augmentation  | Key Driver  | Real Cost (\$M) <sup>44</sup> |
|---|------------|--|---|-------------------------------|
| 2023  | Picton     | Extension of the 132kV busbar, including a new 132kV bus coupler to facilitate the connection of a new terminal transformer. | Address asset condition & system security issues within the Picton South region.                  | \$14.8                        |
|   |            | Installation of a new 132kV transformer bay and new 132/66/22kV 100MVA terminal transformer.                                 |   |                               |
| 2024  | Busselton  | Installation of 24MVAR dynamic reactive support devices (i.e. STATCOM) and associated 66kV step-up transformer.              | Address voltage related N-1 non-compliances.<br>Increase Picton South maximum supportable demand. | \$18.0                        |
| 2025  | Picton     | Decommission and remove the both old Picton terminal transformers.   | Address asset condition & system security issues within the Picton South region.                  | \$11.6                        |
|   |            | Installation of a new 132kV transformer bay and 132/66/22kV 100MVA terminal transformer.                                     |   |                               |
|   | Busselton  | Replace 3 x 66/22kV smaller transformers (T1, T2 & T3) with a single larger 66/22kV 33MVA transformer.                       | Address asset condition issues.   | \$7.2                         |
|   |            | Decommission and remove the 3 x 66/22kV transformers.  |   |                               |
| 2027  | Busselton  | Installation of an additional 8MVAR of dynamic reactive support devices (i.e. STATCOM).                                      | Address voltage related N-1 non-compliances.<br>Increase Picton South maximum supportable demand. | \$5.3                         |
|   |            | Installation of a 5MVAR 22kV capacitor bank and associated equipment.  |   |                               |
|   | Capel      | Installation of a new 66/22kV 33MVA transformer.   | Address asset condition issues.   | \$8.6                         |
|   |            | Decommission and remove the existing 66/22kV transformers, T1 and T3.  |   |                               |
| 2056  | Picton     | Replace the remaining 66/22kV transformer (T4) at Picton with a new 132/22kV 33MVA transformer.                              | Address asset condition issues.   | \$6.8                         |
| <b>Total NPC (including risk and escalation) - \$161.5M</b> |            |  |   |                               |

<sup>44</sup> Total capital cost - Including risk and labour on costs

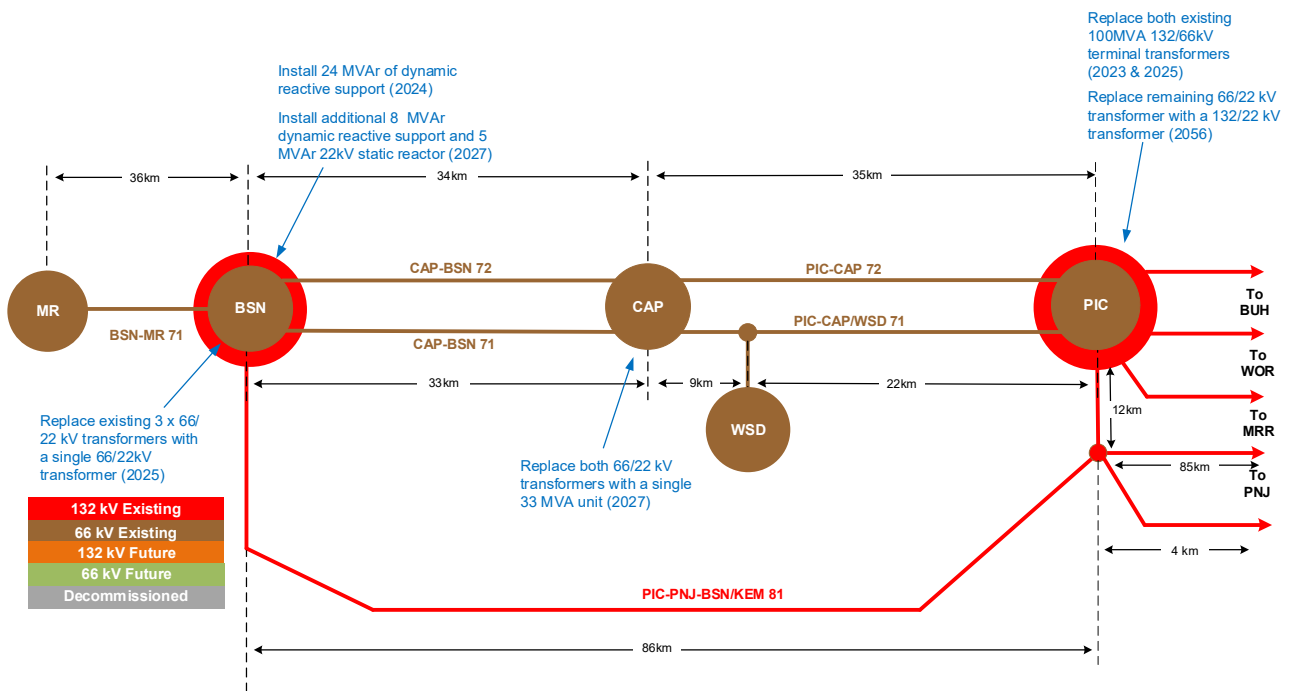

Figure 17 Development Strategy 5 - Scope overview

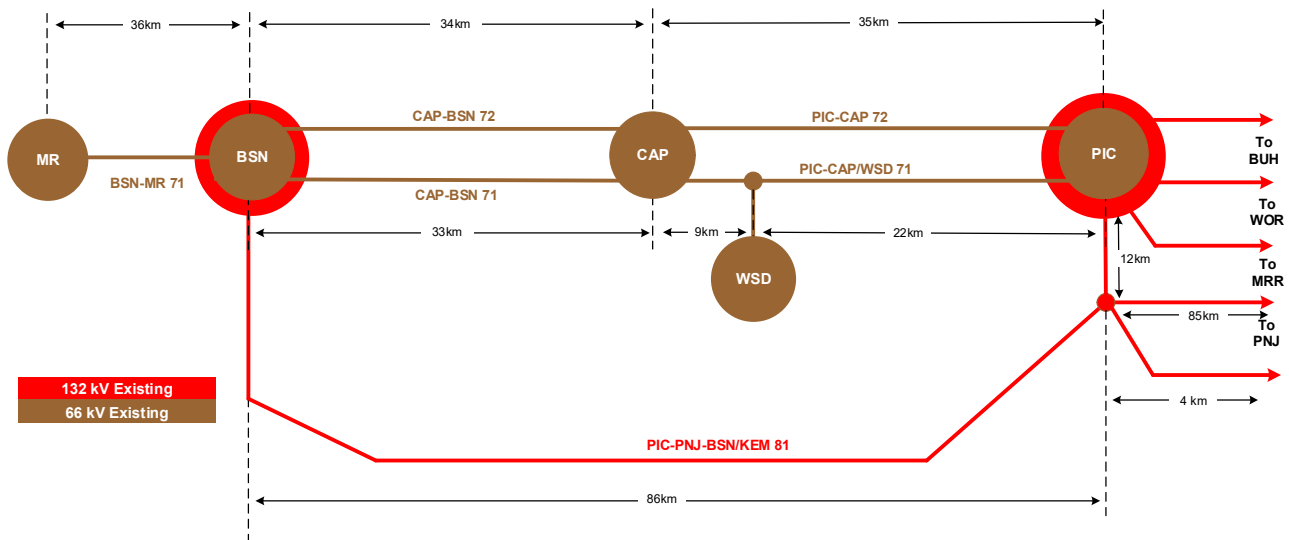

Figure 18: Development Strategy 5 – Final network configuration

## 5.9 Managing Risks Prior to Construction

Prior to the execution of the investments covered within each development strategy, Western Power has several mitigations plans to manage the safety, reliability of supply and system security risks. In some cases, these have also been used to defer investment to date.

### Asset condition risk (Picton Terminal transformers)

As per Western Power’s planning process, a detailed contingency plan, covering multiple scenarios, will be developed to manage the risk of an early failure of one or both these transformers. In the interim, Western Power has identified several plans to mitigate the risk, of which, some have already progressed, including:

- Several on-site short-term treatments are planned prior to the replacement of the transformers.

- Reduced transformer loading – The Picton T3 and T5 transformers will be progressively replaced and upgraded to 132kV supply, resulting in a reduced loading of the terminal transformers. As the loading on a transformer is a major contributing factor to the aging of the transformer, the resupply of the entire Picton demand at 132kV is expected to have some benefits in managing the risk of premature failure to the Picton terminal transformers.
- Procurement of a 100MVA 132/66/22kV transformer to reduce the risk associated with long lead time assets.

### **Voltage limitations**

- An existing operational instruction (first employed in 2010) pre-contingently splits the Busselton 66kV and 132kV network when the demand levels in the area approach unacceptable limits defined in section 3. Although these measures temporarily manage the risk of sustained low voltages, excessive voltage step and voltage stability issues, the network is non-compliant and is operating in an unsecured state.
- To minimise potential equipment damage from sustained low voltages, Under Voltage Load Shedding (UVLS) schemes exist on the 132kV and 66kV busbars at Busselton and Margaret River substations which shed load to bring voltage back to acceptable limits.

## **5.10 Comparison of Development Strategies**

Using a set of key criteria, a comparison of the five development strategies presented in section 5 is shown in Table 5.6. A more detailed cost comparison is discussed within section 7.

**Table 5.6: Comparison of Development Strategies**

| <b>Criteria</b>                 | <b>Comparison of Development Strategies</b>  |
|---------------------------------|--|
| Net Present cost                | All 132kV conversion development strategies present lower NPC pathways than retaining the network at 66kV over the long term, with Development Strategy 2 representing the lowest NPC of all pathways.   |
| Asset Condition                 | All development strategies adequately address the existing and emerging asset condition. The 132kV development strategies eliminate the reliance on the existing Picton terminal transformers by converting the supplies from Picton through to Busselton to 132kV.  |
| Voltage Capacity                | All development strategies adequately address the existing non-compliances relating to voltage capacity.   |
| Maximum supportable demand      | All development strategies increase the maximum supportable demand to meet the 25 year 'Central' peak demand forecasts for Busselton and Margaret River over the long term. However, Development Strategies 1 -3 provide additional spare capacity above the peak forecasts to accommodate the future growth opportunities in the region. The maximum supportable demand increases from 46MW to 84MW under the full implementation of these investment pathways. |
| Alignment to long term strategy | Development Strategies 4 and 5 fail to achieve the objectives and associated benefits of Western Power's 66kV Rationalisation strategy. All 132kV conversion development strategies provide strong alignment with this strategy, with Development Strategy 1 providing the most, through an accelerated conversion of the supplies between Capel and Busselton.  |

| Criteria                                  | Comparison of Development Strategies  |
|---|---|
| 66kV Asset Base Rationalisation           | <p>Under Development Strategies 4-5, the overall 66kV asset base remains largely unchanged, with similar levels of CAPEX and OPEX expenditure expected in future asset renewal cycles. For a more detailed breakdown into the asset base and associated CAPEX/OPEX levels, refer to Appendix D.</p> <p>Conversely, significant benefits in asset base and future CAPEX/OPEX expenditure levels exist under each of the 132kV development strategies, with Development strategy 1 providing the greatest benefits with an additional 41km of 66kV transmission line assets decommissioned and removed, compared with Development Strategies 2-3.</p> <p>Although Development Strategies 2-3 represent the same reduction in asset base over the evaluation period, the installation of the terminal transformer at Picton in Development Strategy 3, defers both the decommissioning and removal of 26km of Picton-Capel/Westralian Sands 72 line assets and the Picton 66kV substation assets by approximately 35 years. This deferment diminishes the opportunity to avoid future replacement that may arise during this period.</p>   |
| Deferment Opportunity and Regret Cost     | <p>Most of the investments under Development Strategies 4-5 involve like for like replacements. With the difficulty in forecasting block load customer connections and long renewal cycles associated with primary plant assets, the regret costs associated with upgrading the network to 132kV after new 66kV assets have been procured or installed is potentially significant.</p> <p>All 132kV development strategies can accommodate a maximum supportable demand of 84MW into Busselton and Margaret River. Under a negative growth scenario, a third 132kV supply into Busselton would not be required however, Development Strategy 1 would have already committed large upfront capital to construct a new double circuit line between Capel and Busselton, representing a sub-optimal outcome.</p> <p>Although the 12km double circuit rebuild section proposed under Development Strategies 2-3 aligns the long-term network development to support a third 132kV supply into Busselton, it represents a more cost-effective asset replacement plan and therefore is unaffected under a negative growth scenario.</p> <p>Development Strategies 2-3 provide the opportunity to defer the Capel to Busselton line rebuild and other 132kV substation conversion works, should the Picton terminal transformers remain in service longer than expected. However, given the condition of these assets, the opportunity may be limited.</p> <p>Overall, a staged approach to transitioning to 132kV represents a lower regret cost investment pathway, allowing better optimisation of network development with capacity and asset condition drivers.</p> |
| Sensitive to higher levels of peak demand | <p>Development Strategies 4-5 are highly sensitive to increases in peak demand, particularly in the form of new block load customer connections, which are likely to lead to sub optimal network development under these pathways.</p> <p>The procurement of NCS is expected to be for a fixed amount over a fixed period. However, if a large new block load connection occurred after the NCS contract was executed, the NCS procured may no longer be sufficient nor be modified to cater for the proposed new load.</p> <p>With the network already operating very close to its voltage capacity limit, additional reactive support devices proposed under Development Strategy 5 provide diminishing marginal benefits in respect to increasing maximum supportable demand in the region.</p> <p>All 132kV development strategies provide additional spare capacity above the forecast peak demand up to 84MW into Busselton and Margaret River. However, under a high growth scenario, acceleration of the network development to support the construction of a third 132kV supply into Busselton increases maximum demand to 118MW.</p> <p>Each of 132kV development strategies can be accelerated to accommodate a third 132kV supply line, with Development Strategy 1 requiring the least amount of additional works but representing a higher NPC option overall. As it is unclear when or if this is required, a staged 132kV transition is considered a more cost-effective pathway forward.</p>   |

| Criteria              | Comparison of Development Strategies   |
|-----------------------|--|
| Network fault levels  | <p>Retention of the existing 66kV network under Development Strategies 5 maintains the existing network equipment fault levels, eliminating any need uprate equipment with higher fault rating capability within the Picton South transmission and distribution networks.</p> <p>Conversely, network fault levels on the Busselton 66kV and 132kV are expected to increase as a result of the proposed network upgrades under development strategies 1 -3. Although the existing transmission equipment is rated to accommodate these increased fault levels, protection studies have identified the need for upgrades on 22kV Busselton distribution network. Works identified to address these issues are minimal, with protection setting changes and low volumes of conductor upgrades required.</p> <p>The procurement of NCS (through generation) under Development Strategy 4 is expected to trigger similar increases to network fault levels and subsequent reinforcement works on the 22kV Busselton distribution network.</p>   |
| Network Reliability   | <p>An additional terminal transformer is proposed at Busselton under Development Strategies 1-2 to mitigate the risk of a failure of a single Picton terminal transformer. This installation of this transformer also provides additional benefits with respect to increased levels of reliability performance to Margaret River customers, as they are currently supplied via a single transformer and supply line<sup>45</sup>.</p> <p>Development Strategy 3 proposes to relocate the Picton terminal transformer to Busselton once the remaining 66kV circuit is either upgraded to 132kV or decommissioned however, the associated reliability benefits will only be realised approximately 30 years after they would under Development Strategies 1-2.</p> <p>With no growth drivers to trigger an N-1 supply to Margaret River, no second 132/66kV Busselton terminal transformer has been proposed under Development Strategies 4-5, resulting in similar levels of reliability performance to the customers supplied by Margaret River.</p>   |
| Strategic Spares      | <p>Maintaining 66kV assets over the longer term under Development Strategies 4-5 will result in higher overall costs to the business, due to higher volumes of strategic spare assets being required.</p>  |
| Environmental Impacts | <p>Development Strategies 2-3 propose the construction of 12km double circuit transmission line circuit along a new line corridor and a new 3km 66kV line section to resupply Westralian Sands, which has the potential to present environmental risks associated with clearing of natural habitat for the endangered black cockatoo and ringtail possum in the area.</p> <p>Net environmental impacts under these investment pathways are expected to be close to neutral as these works facilitate the decommissioning and removal of ~51km of 66kV line assets between Picton to Busselton. Removal of these lines will allow the natural environment in these areas to be rehabilitated.</p> <p>Similar environmental impacts are expected under Development Strategy 1 however, an additional 41km of 66kV line assets between Capel and Busselton can be decommissioned and removed, of which, approximately 5km traverses through the environmentally sensitive Tuart State Forest.</p> <p>Works proposed under Development Strategies 4-5 are predominately within the existing substation sites, with no material environmental impacts are expected.</p> |

<sup>45</sup> Despite a N-0 supply to Margaret River Substation, DTC is available from Busselton and Beenup Substations. However, this is limited during peak demand conditions.

| Criteria                                 | Comparison of Development Strategies   |
|--|--|
| Transmission Line Corridor and Easements | <p>Development Strategy 1 requires a 33km corridor and easement for the new 132kV double circuit into Busselton however, where possible, will follow the alignment of the existing 66kV line circuits.</p> <p>Development Strategies 2-3 are also expected to require a new corridor and easement for the new 12km 132kV rebuild section.</p> <p>Although Development Strategies 4-5 propose like for like replacements, conductor and pole replacements are constrained by construction outages, which may trigger the need to rebuild the parts of the line at an offset to the existing easement, potentially triggering some environmental impacts. However, these are expected to be minor.</p>   |
| Complexity of solution/Delivery risk     | <p>Due to the installation of new transmission line assets, Development Strategies 1-3 are expected to require significant stakeholder engagement, careful optimisation of works, effective community engagement and outage coordination, which generally has an increased level of complexity than works to maintain the existing 66kV network topology.</p> <p>Development Strategy 3 represents a higher level of deliverability risk than Development Strategy 2, due to the design and timing interdependencies that the replacement of the Picton T3 and T5 transformers have with the proposed installation of a new terminal transformer. Changes in scope or delays in delivery will adversely impact the installation of the new terminal transformer.</p> |
| Dynamic support devices (STATCOM)        | <p>All development strategies, other than Development Strategy 4 propose the installation of dynamic support devices (i.e. STATCOM). These devices have capability to deliver up to a 200% short term overload of their full output.</p>   |
| Network Strength/Losses                  | <p>Development Strategies 1-3 represent a stronger network than Development Strategies 4-5, with lower overall network losses expected under these pathways.</p>   |
| Operational flexibility                  | <p>With both Picton and Busselton already on a pathway to 132kV, future like for like transformer replacements at 66kV can present operational challenges.</p> <p>For example, during peak conditions, following a transformer contingency to one of the 132kV Picton transformers, the temporary paralleling of the Picton 22kV busbar to energise the 66/22kV transformer (operating on cold standby) will result in the remaining 132/22kV transformer experiencing a short term overload of 148% (125% when Capel is upgraded to 132kV) as it partially supplies the 66kV network and existing Picton load.</p> <p>These issues do not exist for Development Strategies 1-3.</p>   |
| Future land sales                        | <p>An extension of the existing Picton substation site is required to accommodate the extension of the 132kV busbar and new terminal transformer under Development Strategies 3-5. The non-standard site dimensions have the potential to reduce future land sales.</p>  |



## 6. Format and Inputs to Analysis

### 6.1 Regulatory Test Requirements

Under Chapter 9 of the Electricity Networks Access Code (2004), the Regulatory Test assesses whether a proposed Major Augmentation to a covered network maximises the Net Benefit to those who generate, transport or consume electricity after considering alternative options.

Western Power's proposed major augmentation is considered defensible if it applies the Regulatory Test properly, using reasonable modelling scenarios. Western Power must also use reasonable timings for project commissioning dates and construction timetables.

The ERA Regulatory Test Guidelines<sup>46</sup> provide direction in identifying methods for determining which option maximises Net Benefits. Areas to be considered for analysis should include, but are not limited to:

- Construction, operation and maintenance costs;
- Changes to fuel consumption, arising through different generation dispatch;
- Changes in voluntary load curtailment, caused through reduction in demand side curtailment;
- Changes in ancillary services; and
- Changes in involuntary load shedding, caused through savings in reduction in lost load.

### 6.2 Network Augmentation Costs

The financial analysis considers all foreseeable cost impacts of the proposed network augmentations. The cost to implement each of the feasible options outlined in section 5 of this document has been estimated by Western Power. The capital and operating cost estimates utilised in this assessment have been derived from a combination of Western Power estimating building blocks and forecast expenditure models that are benchmarked against previous projects with common scope elements.

Western Power building block cost estimates have been developed using the Western Power Benchmarking & Evaluations' Success Estimator Software, Western Power's database for standard design, typical engineering parameters, through investigation of historical cost figures and typical expenditure, and previous commercial procurement and tendering processes.

Where required, subject matter expert input was sought within Western Power on specific items to reduce estimate accuracy tolerances. A sensitivity analysis for the cost estimates of each option has been included in section 7.3 of this document.

### 6.3 Other

While this Regulatory Test focuses on the investments in the Picton South region to address the range of network risks in the short to medium term, economic analysis performed over a 50-year evaluation period provides equivalency in comparing options and demonstrate the robustness over the longer term.

The timing of some of the capacity related components for each strategy are based on meeting Western Power's forecast peak demand. Actual timing of anticipated investments may change because of the ongoing review of forecast demand for the Picton South area, during the assessed planning horizon.

---

<sup>46</sup> Refer to <https://www.erawa.com.au/electricity/electricity-access/guidelines/regulatory-test-guidelines>

## 7. Financial Analysis

The economic analysis undertaken considered the NPC of all options over the 50-year period, with 2018/19 as the base year.

### 7.1 Net Present Cost

The previous sections of the Options Paper have presented the details of the individual development strategies for the Picton South region, including key technical and financial parameters considered. This section focuses on the costs of each development pathway, while taking into consideration the associated benefits of each investment pathway to identify the optimal strategy for the Picton South region over the assessed timeframe.

Table 7.1 shows the NPC's for each of the presented development strategies. It is evident from this table that the strategy with the lowest NPC over the long term is Development Strategy 2.

**Table 7.1: Economic assessment of proposed development strategies**

| # | Development Strategy                                      | NPC (\$M) |
|---|---|-----------|
| 1 | Accelerated 132kV conversion                              | 156.1     |
| 2 | Staged 132kV conversion - Busselton terminal transformer  | 143.6     |
| 3 | Staged 132kV conversion - Picton terminal transformer     | 148.9     |
| 4 | Retain 66kV network – Procure NCS                         | 174.1     |
| 5 | Retain 66kV network – Install additional reactive support | 161.5     |

Retention of the 66kV network under Development Strategies 4 and 5 represent the higher NPC pathways than the 132kV conversion development strategies. The potential regret costs under these pathways are high, as they are highly sensitive to increased levels of peak demand, particularly with block load type connections.

Additionally, these development strategies do not provide any additional spare capacity above the forecast peak demand to accommodate future growth opportunities in the area, nor do they provide any significant benefits from reductions to the existing asset base. Subsequently, these pathways are not recommended.

Development Strategy 1 accelerates the Picton South networks transition to 132kV and although it provides the greatest benefits in terms of rationalising the Picton South 66kV asset base, the NPC of this pathway is the highest of the 132kV conversion pathways. Compared with the staged 132kV development strategies, the regret costs are higher due to the possibility that higher growth drivers do not eventuate and trigger the need for a third 132kV supply into Busselton.

Although the individual investments under Development Strategies 2 and 3 are very similar, a second terminal transformer at Busselton Substation, rather than at Picton, represents lower installation costs and provides the additional benefit of facilitating an earlier decommissioning of the Picton 66kV substation assets and part of the existing Picton-Capel 72 line.

Overall, Development Strategy 2 represents an optimised network plan that is lower in NPC to address the supply and system security risks in the Picton South region over the long term, while maximising network benefits, compared to the alternative options.

Figure 19 and Figure 20 illustrate the nominal capital expenditure over a 10 year and 50 year period for each of the identified development strategies, including the capital expenditure for the forecast asset replacement works.

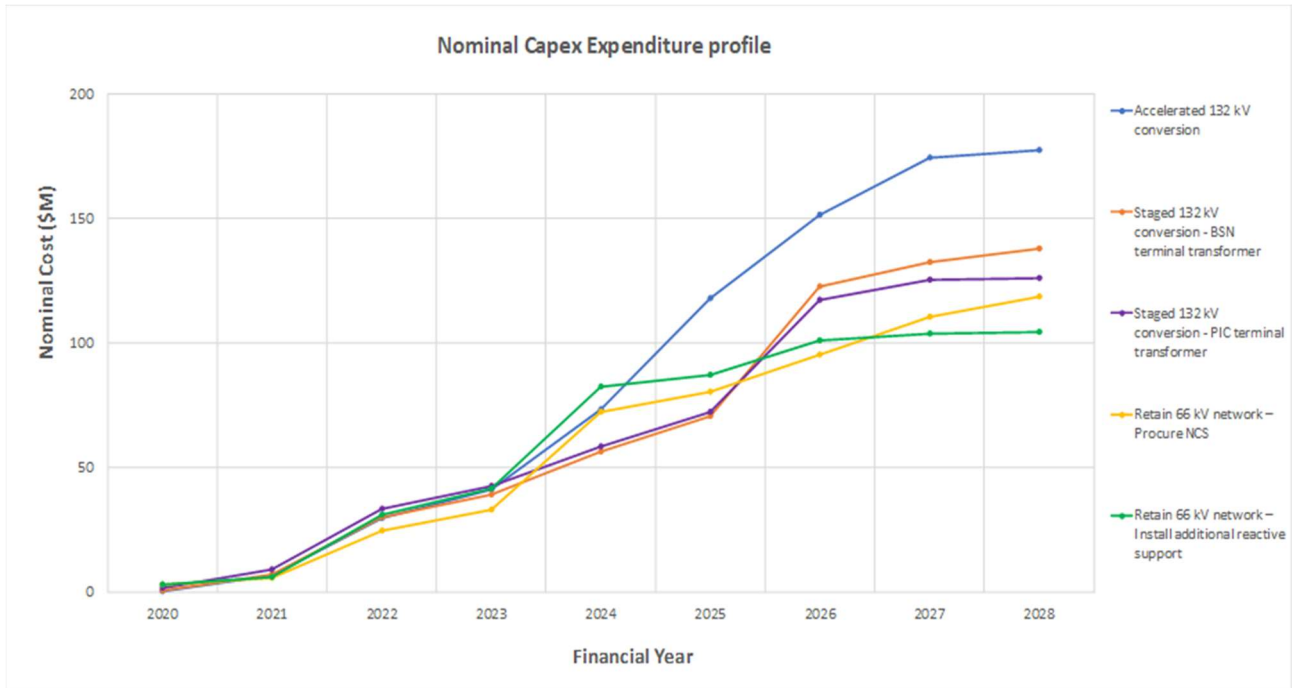

Figure 19: Cumulative nominal CAPEX expenditure profiles – 10-year period

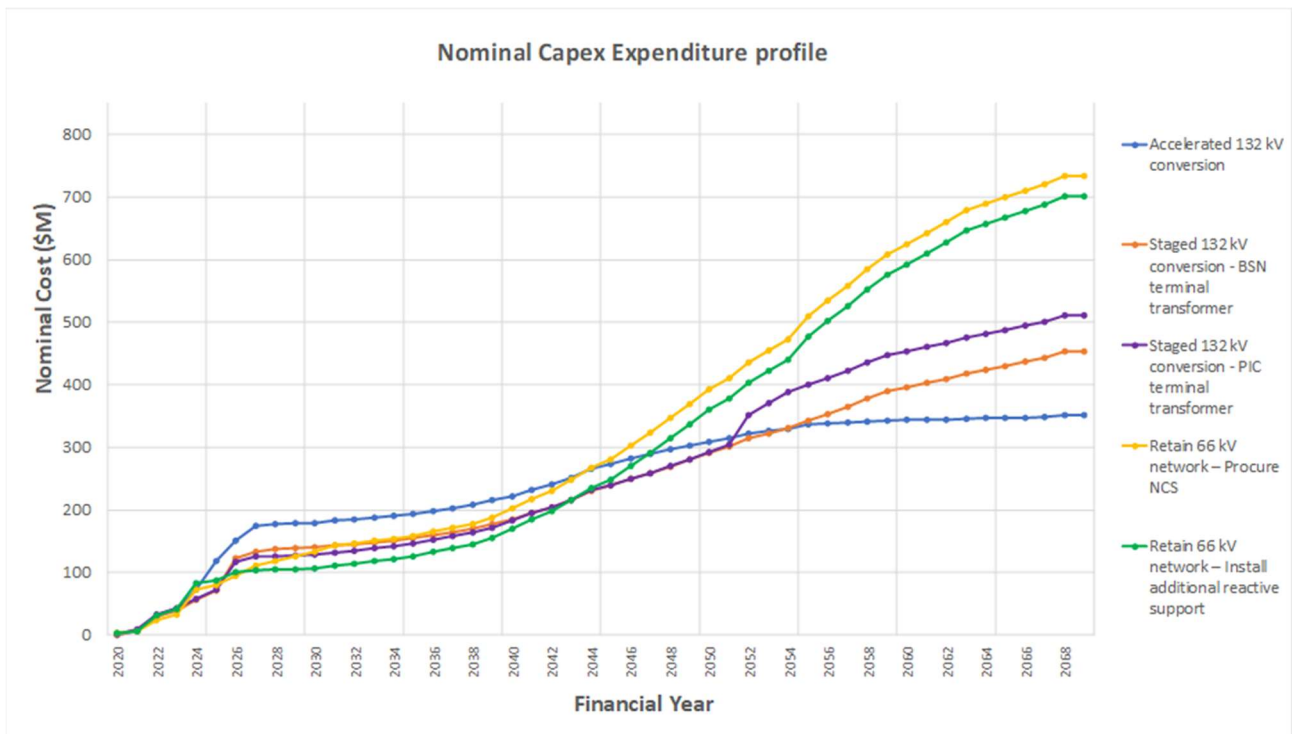

Figure 20: Cumulative nominal CAPEX expenditure profiles – 50-year period

Although the development strategies have several common investments, there are distinct differences with the nominal capital expenditure profiles over the next 10 years.

Development Strategy 1 requires the greatest upfront nominal capital investment in the first ten years compared to all the alternative pathways. The expenditure profiles for Development Strategies 2-3 are similar over the first ten years, which is also reflective of their NPC's over the longer term.

Development Strategy 5 requires the lowest nominal capital expenditure over the first ten years however, along with Development Strategy 4, will require much higher capital investment to retain the 66kV network than all the 132kV conversion development strategies, as shown by Figure 20. Lastly, Development Strategy 1 represents the lowest nominal capital investment over 50 years however, the NPC for this pathway is higher than Development Strategies 2 and 3.

## 7.2 Cost Building Blocks

The total capital cost calculated for each development strategy has been produced using Western Power's estimating building blocks. The building blocks provide an average cost based on historical values but are not fully detailed and do not include any site-specific requirements. It is expected that these costs would be subject to a degree of variation and revision when developed in detail. In addition, where building blocks are not available, Western Power has produced costs for unique scope items based on commercially benchmarked information.

The costs considered in the development strategy comparisons have generally been prepared with a tolerance of  $\pm 50\%$  however, the investments recommended to progress forward with under this Options Paper, have been further refined to a tolerance of  $\pm 30\%$  through Western Power's estimation process.

Cost sensitivity analysis on the NPC was also undertaken using Western Power's Investment Evaluation Model (IEM) with a variance of  $\pm 20\%$  to the overall expenditure across the evaluation period. This is illustrated in Table 7.2.

Cost sensitivity analysis on each of the development strategy investment pathways indicated that Development Strategy 2 is robust to cost variations, and therefore remains the most financially prudent (and recommended) development strategy option when assessed under these scenarios.

**Table 7.2: NPC Sensitivity Analysis on total capital expenditure (\$M)**

| # | Development Strategy                                      | Base Case | Ranking | High State (+20%) | Ranking | Low State (-20%) | Ranking |
|---|---|-----------|---------|-------------------|---------|------------------|---------|
| 1 | Accelerated 132kV conversion                              | 156.1     | 3       | 174.6             | 3       | 137.5            | 4       |
| 2 | Staged 132kV conversion - Busselton terminal transformer  | 143.6     | 1       | 162.2             | 1       | 125.0            | 1       |
| 3 | Staged 132kV conversion - Picton terminal transformer     | 148.9     | 2       | 168.3             | 2       | 129.4            | 2       |
| 4 | Retain 66kV network – Procure NCS                         | 174.1     | 5       | 200.2             | 5       | 148.0            | 5       |
| 5 | Retain 66kV network – Install additional reactive support | 161.5     | 4       | 186.2             | 4       | 136.9            | 3       |

## 7.3 Demand Growth

Although the Picton South network development is primarily being shaped by asset condition drivers, network reinforcement is required to address the existing voltage capacity limitations that arise during peak demand conditions, following the loss of the single 132kV supply into Busselton.

Western Power’s peak demand forecasts depict a slight trend of growth within the Picton South region. Customer demand in this load area is a mix of residential, commercial, industrial and agricultural electricity consumers. Due to the existing network topology, the voltage capacity shortfall is most sensitive to the Busselton and Margaret River substation demand levels. Additionally, these areas are well known tourism destinations. The Capel region has multiple mining operations supplied by the Western Power network, which contribute to the state economy. The Picton South area is most sensitive to block load connections in Margaret River, Busselton and Capel (in descending order of impact).

The capacity benefits realised through the preferred development strategy, Development Strategy 2, addresses the existing voltage capacity constraints and caters for future load growth, while also providing asset rationalisation benefits the Picton South 66kV asset base.

Demand growth sensitivity analysis has been performed across each of the development strategies, considering both high and negative growth scenarios, which represent a +46% and -37% variance to the ‘Central’ peak demand forecast over the next 25 years. The sensitivity analysis performed caters for a large variance to the Central peak demand forecast to help test the robustness of the development strategies to large changes in growth drivers over the long term, despite the likelihood of these scenarios eventuating being low.

The high growth scenario is based on demand level of 106MW, represents the level of aggregate demand at Busselton and Margaret River that could be supported by a third 132kV supply into Busselton, without any additional reactive support devices. Conversely, the negative growth scenario is based upon the level of aggregate demand at Busselton and Margaret River falling to 46MW. The existing network topology does not have any voltage capacity constraints at this low level of peak demand.

Table 7.3 illustrates the outcomes of the demand growth sensitivity analysis on the NPC and provides a relative ranking.

**Table 7.3: Demand Growth Sensitivity Analysis – Summary**

| # | Development Strategy                                     | Central Case NPC (\$M) | Ranking | Negative Growth Case NPC (\$M) | Ranking | High Growth Case NPC (\$M) | Ranking |
|---|--|------------------------|---------|--------------------------------|---------|----------------------------|---------|
| 1 | Accelerated 132kV conversion                             | 156.1                  | 3       | 142.9                          | 3       | 180.3                      | 2       |
| 2 | Staged 132kV conversion - Busselton terminal transformer | 143.6                  | 1       | 130.5                          | 1       | 171.3                      | 1       |
| 3 | Staged 132kV conversion - Picton terminal transformer    | 148.9                  | 2       | 136.9                          | 2       | 180.5                      | 3       |
| 4 | Retain 66kV network – Procure NCS                        | 174.1                  | 5       | 143.9                          | 4       | 224.2                      | 4       |

| # | Development Strategy                                      | Central Case NPC (\$M) | Ranking | Negative Growth Case NPC (\$M) | Ranking | High Growth Case NPC (\$M) | Ranking |
|---|---|------------------------|---------|--------------------------------|---------|----------------------------|---------|
| 5 | Retain 66kV network – Install additional reactive support | 161.5                  | 4       | 143.9                          | 4       | 252.7                      | 5       |

The results of the sensitivity analysis include the following findings:

- Overall, there is minimal impact to the NPC and relative ranking for each development strategies, due to the majority of the investments relating to addressing asset condition drivers, which are unaffected by the sensitivity analysis performed. However, the sensitivity analysis directly impacts the maximum supportable demand requirements.
- Under a high growth scenario, the NPC under Development Strategy 5 increases significantly due to the thermal issues that arise on the Capel-Busselton 71 & 72 line circuits to allow the installation of further reactive support devices.
- The demand growth sensitivity analysis demonstrates that even under a broad high and negative growth scenario, Development Strategy 2 remains the most prudent and efficient investment pathway to mitigate the issues identified in the Picton South region over the long term.

Further details on the growth sensitivity analysis is provided in Appendix E.

## 8. Conclusions

The following conclusions have been drawn from the analysis presented in this report:

1. Planning studies were undertaken to evaluate potential network options to address the future supply requirements in the Picton South network. Five development strategies were evaluated against a range of financial and technical performance metrics to determine the most efficient and prudent investment pathway.
2. The 'Do nothing' option has been considered but is discounted as it does not address any of the identified asset condition and voltage capacity related limitations in the Picton South region, exposing Western Power to multiple safety, reliability of supply, system security and compliance risks.

Failure to address the risks associated with the Picton terminal transformers will result in an inability to meet the peak demand to the approximately 46,000 customers supplied within the region (of which 81 are on life support), followed by significant periods of rotational load shedding that will result in adverse impacts on customers experience and reduced economic activity in the area. Furthermore, this option is not consistent with good industry practice and Western Power's obligations to comply with the requirements of the Technical Rules and the Electricity Networks Access Code 2004.

3. All development strategies presented in section 5 address the identified safety, reliability of supply, system security and compliance risks in the Picton South region over the long term.
4. Unlike Development Strategies 4-5, Development Strategies 1-3 align to the objectives of Western Power's 66kV Rationalisation strategy, achieving the associated benefits of transitioning to 132kV voltage. Furthermore, these investment pathways provide significant asset rationalisation benefits and subsequent reductions to the CAPEX and OPEX expenditure in the current and future asset renewal cycles, as shown in Appendix C and Appendix D.
5. Under the Development Strategies 1-3, the maximum supportable demand to Busselton and Margaret River increases from 46MW to 84MW, which provides an additional 11MW of spare capacity to accommodate future growth opportunities. The maximum demand under Development Strategies 4-5 only increase to meet the forecast peak demand.
6. Economic analysis performed demonstrates that Development Strategy 2 is the least NPC cost solution over a 50-year evaluation period. Development Strategy 2 is an optimised network plan, representing a lower overall CAPEX/OPEX expenditure than like for like replacements over the long term to addresses the asset condition and voltage capacity related limitations identified in the Picton South region. The results of sensitivity analysis involving variation in cost and peak demand growth also demonstrate an outcome consistent with the base case economic analysis, in that the options ranking does not change.
7. A staged transition to 132kV under Development Strategy 2 progresses network development in the Picton South region along a pathway that is also flexible to respond to increased growth and asset condition drivers, with low regret costs. In addition, the staging sequence of works, provides deferment opportunities and potential cost savings should assets deteriorate at slower rates than expected.
8. The first stage of investments under Development Strategy 2 involve line uprate works between Picton and Capel, resupply of the Westralian Sands Substation at 66kV and the installation of a second Busselton 132/66kV terminal transformer and static and dynamic reactive support devices

at Busselton substation by 2024. The nominal capital cost of this option is \$38.2 million (including project on costs and risk allowance) and is the subject of this Regulatory Test.

9. Upon the completion of the individual investments in this first stage of works, the system security and supply risks associated with a single Picton terminal transformer contingency to the Picton South area will be addressed. Additionally, the network will achieve N-1 network compliance and the maximum supportable demand at Busselton and Margaret River will increase to 73MW, which meets the forecast peak demand over the long term.
10. The subsequent stages of works to completely convert the supplies between Picton and Busselton to 132kV will address the failure of both Picton terminal transformers, providing additional asset rationalisation and further increases to the Busselton and Margaret River maximum supportable demand from 73MW to 84MW.
11. Western Power must plan, and coordinate works to allow adequate lead time to ensure a reliable and secure electricity supply to the Picton South region is achieved through the implementation of the preferred development strategy to meet in-service requirements.



## 9. Draft Recommendation

Based on the option analysis and Western Power's obligations under the Electricity Networks Access Code 2004 for major augmentations, it is recommended that the following investments be progressed under the recommended network development pathway, Development Strategy 2:

### By 2022:

- Uprate of the Picton-Capel 71 line to support future energisation at 132kV including:
  - Upgrade electrical fittings and post insulators to 132kV specification
  - Uprate 2.5km earthwires along the Picton-Capel 71 and 72 line circuits
- Transfer Westralian Sands 66kV tee-line from Picton-Capel/Westralian Sands 71 to Picton-Capel 72 transmission line via the construction of a new 3km 132kV rated (energised at 66kV) wood pole single circuit with 'Lemon' conductors.

### By 2023:

- Extension of the existing 132kV busbar at Busselton substation, including a new 132kV disconnecter
- Installation of a new 132kV Tx bay and 100MVA 132/66/22kV transformer at Busselton substation

### By 2024:

- Installation of a static and dynamic reactive support devices at Busselton substation including:
  - Install 1 x (+/-) 12MVAR of dynamic reactive support devices (i.e. STATCOM) and associated step-up transformer equipment
  - Install 10MVAR capacitors and associated plant on tertiary winding of new Busselton 132/66kV transformer

The nominal capital cost of this option being \$38.2 million (including project on costs and risk allowance) is the subject of this Options Paper and subsequent Regulatory Test Submission. This cost has been determined as part of the Western Power's detailed cost estimate process.

The solution represents an optimised plan that is lower in cost than a like for like replacement plan and is a key decision that sets the investment direction for the entire Picton South region, ensuring asset condition, non-compliances and the capability to accommodate future growth over the long term is addressed in a timely manner.

It should be noted that the recommended strategy for the Picton South network is Development Strategy 2 and that the investments identified within it will be taken forward in due course. Some of these investments may be subject to future Regulatory Tests.

Upon the completion of this first stage of investments, the system security and supply risks associated with a single Picton terminal transformer contingency will be addressed. Additionally, the network will achieve N-1 network compliance and will initially increase maximum supportable demand at Busselton and Margaret River to 73MW, which meets the forecast peak demand over the long term.

The remaining investments of the development strategy consist of further asset replacement works and the complete conversion of one of the existing 66kV line circuits to 132kV. Upon energisation of the new 132kV supply into Busselton, the security of supply risks associated with the loss of both Picton terminal transformers will be completely addressed. Furthermore, the completion of these works will provide additional benefits including further asset rationalisation and increasing maximum supportable demand further from 73MW to 84MW, providing enough spare capacity to accommodate future growth opportunities.

## 10. Consultation

In accordance with the Electricity Networks Access Code 2004, Western Power invites submissions from all interested parties on this Options Paper.

Please address all submissions to [Picton.South@westernpower.com.au](mailto:Picton.South@westernpower.com.au).

## Appendix A: Asset Condition Criterion

**Table A.1: Asset condition criterion**

| Asset class                  | Methodology   | Condition Ratings  |
|------------------------------|---|--|
| Power Transformers           | <p>Survival life analysis of individual units based on the following techniques:</p> <ul style="list-style-type: none"> <li>• Visual and thermographic inspections;</li> <li>• High voltage diagnostic tests;</li> <li>• Oil testing including dissolved gas analysis (DGA) and oil quality testing;</li> <li>• High voltage testing of bushings;</li> <li>• Maintenance;</li> <li>• Tap changer type / performance history;</li> <li>• Moisture analysis; and</li> <li>• Online monitoring.</li> </ul> | <p><b>Good</b> – Indicates a condition assessment score <math>\geq 140</math> or between 9 and 10 (normalised).</p> <p><b>Fair</b> – Indicates a condition assessment score <math>\geq 120</math> or between 7 and 8 (normalised).</p> <p><b>Poor</b> – Indicates a condition assessment score <math>\geq 100</math> or between 5 and 6 (normalised)</p> <p><b>Bad</b> – Indicates a condition assessment score <math>&lt; 100</math> or between 0 and 4 (normalised).</p> |
| Switchboards/<br>Switchgear  | <p>Condition assessment based on:</p> <ul style="list-style-type: none"> <li>• Age;</li> <li>• Defect frequency;</li> <li>• Known performance issues;</li> <li>• Busbar, cable box, insulation type;</li> <li>• Known maintenance issues;</li> <li>• Obsolescence;</li> <li>• Spare part availability; and</li> <li>• Number of operations (for circuit breakers).</li> </ul>   | <p>Holistic categorisation of asset condition into <b>Good, Fair, Poor or Bad</b> condition considering appropriate weights for influencing factors.</p>   |
| Transmission Lines           | <p>Condition assessment based on:</p> <ul style="list-style-type: none"> <li>• Corrosion;</li> <li>• Strand degradation;</li> <li>• Conductor annealing;</li> <li>• Assessment of hot joints;</li> <li>• Metal fatigue; and</li> <li>• Mechanical wear.</li> </ul>  | <p>Asset defect severity rating assigned based on condition assessment</p>   |
| Transmission Line Structures | <p>Condition assessment based on:</p> <ul style="list-style-type: none"> <li>• Decay or deterioration;</li> <li>• Structural integrity;</li> <li>• Corrosion;</li> <li>• Concrete cancer;</li> <li>• Splits;</li> <li>• Cracks, surface degradations or chips; and</li> <li>• Soil erosion and physical movement.</li> </ul>  | <p>Asset defect severity rating assigned based on condition assessment and structural attributes (e.g. age, type of wood, existing reinforcements).</p>  |

# Appendix B: Transmission Line Asset Information

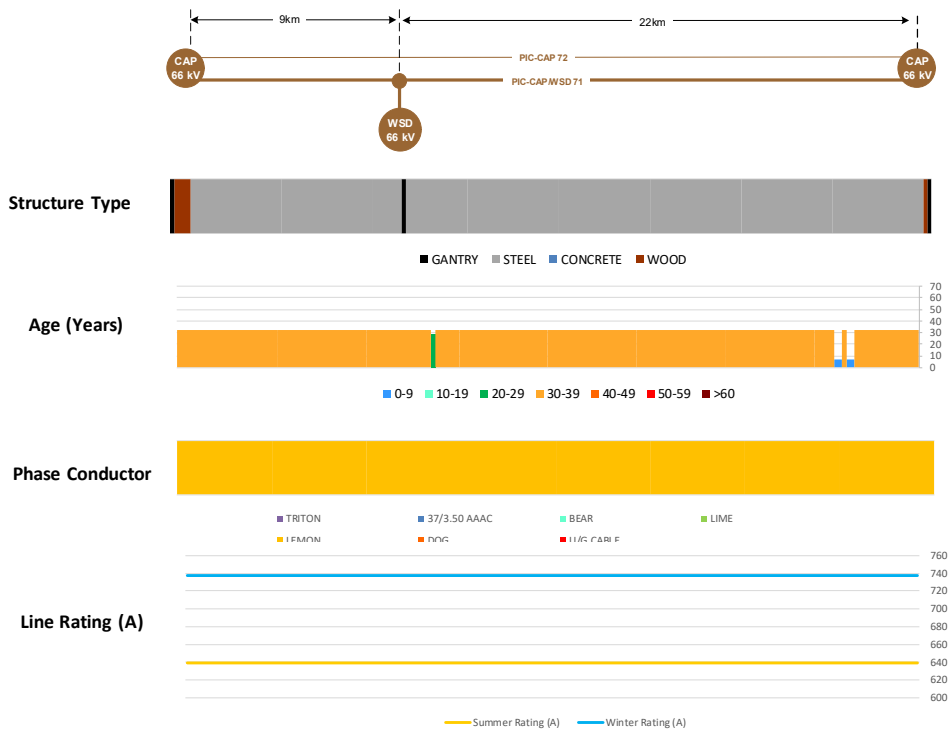

Figure 21: Picton-Capel/Westralian 71 transmission line asset information

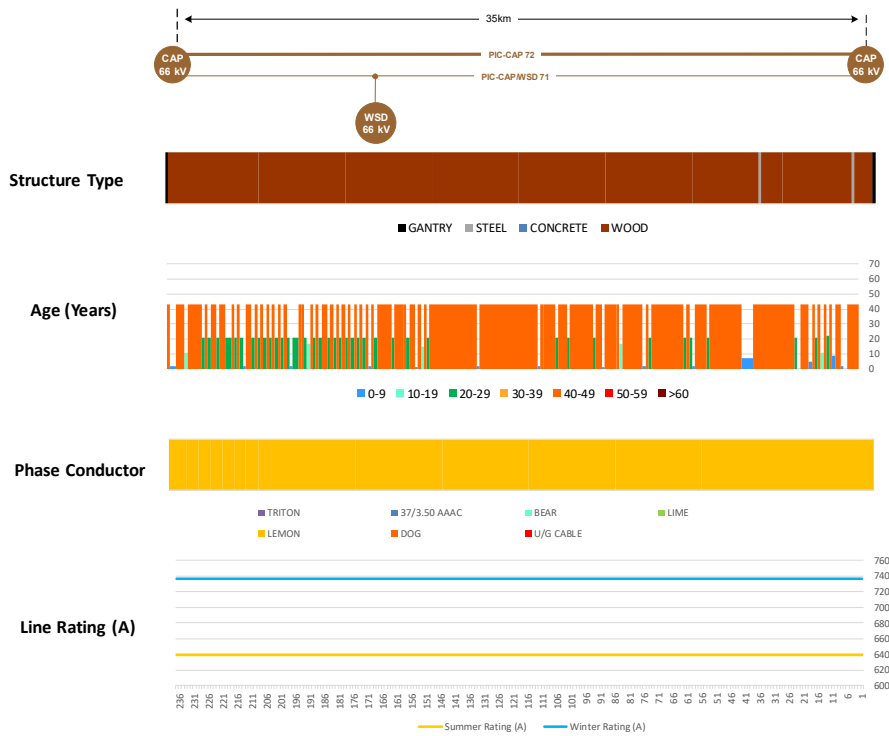

Figure 22: Picton-Capel 72 transmission line asset information

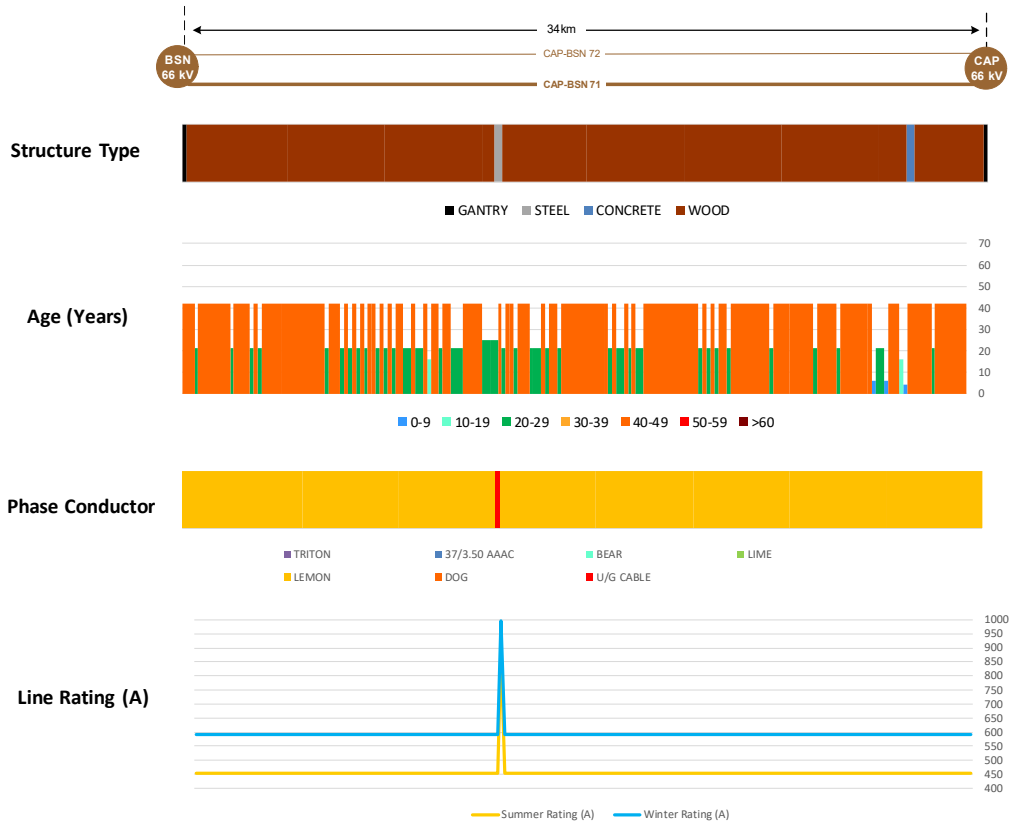

Figure 23: Capel-Busselton 71 transmission line asset information



Figure 24: Capel-Busselton 72 transmission line asset information



Figure 25: Picton-Pinjarra-Busselton/Kemerton 81 (Busselton end) transmission line asset information

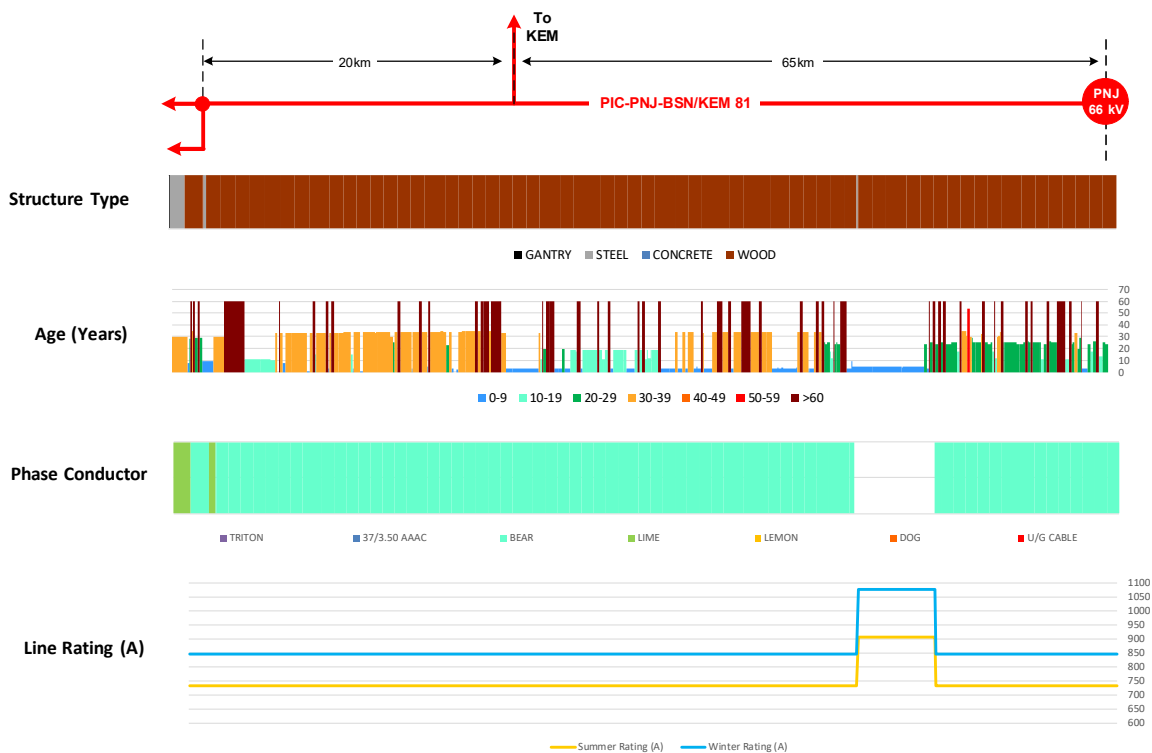

Figure 26: Picton-Pinjarra-Busselton/Kemerton 81 (Pinjarra end) transmission line asset information

## Appendix C: Asset Base Rationalisation

Table C.1 and Table C.2 provide a summary of the asset rationalisation over a 50 year evaluation period, relative to the existing 66kV Picton South asset base for each of the development strategies presented in section 5.

**Table C.1: Picton South – 66kV Asset base rationalisation (50-year evaluation) – Transmission Plant**

|                    | Asset Type                  | 132kV Development Strategies |            |            | 66kV Development Strategies |            |
|--------------------|-----------------------------|------------------------------|------------|------------|-----------------------------|------------|
|                    |                             | 1                            | 2          | 3          | 4                           | 5          |
| Transmission Plant | Terminal transformer        | -1                           | -1         | -1         | 0                           | 0          |
|                    | Zone substation transformer | -3                           | -3         | -3         | -2                          | -2         |
|                    | STATCOM                     | +1                           | +1         | +1         | 0                           | +1         |
|                    | Capacitor banks             | +2                           | +2         | +2         | +1                          | 0          |
|                    | Circuit breaker             | -18                          | -18        | -18        | -3                          | -3         |
|                    | Disconnecter                | -33                          | -33        | -33        | -4                          | -4         |
|                    | Current transformer         | -15                          | -15        | -15        | -2                          | -2         |
|                    | Voltage transformer         | -8                           | -8         | -8         | -1                          | -1         |
|                    | <b>Total Plant</b>          | <b>-75</b>                   | <b>-75</b> | <b>-75</b> | <b>-11</b>                  | <b>-11</b> |

**Table C.2: Picton South – 66kV Asset base rationalisation (50-year evaluation) – Transmission Lines**

|                    | Asset Type                       | 132kV Development Strategies |     |     | 66kV Development Strategies |   |
|--------------------|----------------------------------|------------------------------|-----|-----|-----------------------------|---|
|                    |                                  | 1                            | 2   | 3   | 4                           | 5 |
| Transmission Lines | Transmission line circuit (km's) | -91                          | -51 | -51 | 0                           | 0 |

## Appendix D: Asset Replacement Expenditure

Based on a set of assumptions, asset information and proposed works presented in section 5, Table D.1 provides a summary of the 50 year forecast capital and operating expenditure between Picton and Busselton that take into consideration the network development under each of the investment pathways presented.

The nominal costs presented below only includes the capital and operating expenditure for only power transformer, primary plant and transmission line assets, but does not include the expenditure that is common to all development strategies.

**Table D.1: Forecast capital and operating expenditure – Tx lines and primary plant**

| Dev. Strategy # | Development Strategy Description                          | NPC (\$M) | Expenditure Type (CAPEX/OPEX) | Expenditure              | Base Cost (\$M) – 50-year period |
|-----------------|---|-----------|-------------------------------|--------------------------|----------------------------------|
| 1               | Accelerated 132kV conversion                              | 156.1     | CAPEX                         | Tx Primary Plant & Lines | 84.3                             |
|                 |   |           | OPEX                          | Tx Primary Plant & Lines | 8.0                              |
| 2               | Staged 132kV conversion – Busselton Terminal transformer  | 143.6     | CAPEX                         | Tx Primary Plant & Lines | 125.0                            |
|                 |   |           | OPEX                          | Tx Primary Plant & Lines | 10.6                             |
| 3               | Staged 132kV conversion – Picton Terminal transformer     | 148.9     | CAPEX                         | Tx Primary Plant & Lines | 133.8                            |
|                 |   |           | OPEX                          | Tx Primary Plant & Lines | 14.5                             |
| 4               | Retain 66kV network and Network Control Services (NCS)    | 174.1     | CAPEX                         | Tx Primary Plant & Lines | 227.4                            |
|                 |   |           | OPEX                          | Tx Primary Plant & Lines | 19.9                             |
| 5               | Retain 66kV network and additional reactive power support | 161.5     | CAPEX                         | Tx Primary Plant & Lines | 227.4                            |
|                 |   |           | OPEX                          | Tx Primary Plant & Lines | 19.9                             |



## Appendix E: Demand Growth Sensitivity Analysis

Sensitivity analysis has been performed for each of the development strategy investment pathways, considering variances to the 25-year 2017 peak demand forecasts. The peak demand for the 'High growth' and 'Negative growth' sensitivities scenario has been developed based on the following:

- 'High growth' - This peak demand scenario investigates a high growth scenario and represents the level of demand at Busselton and Margaret River that could be supported by a third 132kV supply line into Busselton, which based on power system studies is equivalent to 106MW (excluding additional reactive support devices).
- 'Negative growth' - This peak demand scenario investigates a strong negative growth scenario which represents the level of demand which can be supported without any voltage capacity constraints arising, which occurs when the aggregate demand at Busselton and Margaret River falls to 46MW. This level of decline in peak demand is likely to be driven by a combination of high residential PV and battery storage uptake, higher levels of equipment efficiency and significant number of customers leaving the grid.

The peak demand levels over the 25 year period for the 'High growth' and 'Negative growth' sensitivity scenarios are shown in Table E.1 and are illustrated in Figure 27. The 'High growth' and 'Negative growth' represent a 46% increase and 37% decrease to the 'Central' peak demand forecast.

**Table E.1: Busselton and Margaret River substation peak demand forecast - Sensitivity analysis**

| Sensitivity  | Busselton and Margaret River peak demand (MW) forecasts |      |      |      |      |      |      |      |      |      |       |
|--------------|---|------|------|------|------|------|------|------|------|------|-------|
|              | 2019  | 2020 | 2021 | 2022 | 2023 | 2024 | 2025 | 2026 | 2027 | 2028 | 2042  |
| High Case    | 60.9  | 62.9 | 64.9 | 66.8 | 68.8 | 70.7 | 72.7 | 74.7 | 76.6 | 78.6 | 106.0 |
| Central Case | 60.9  | 62.7 | 63.5 | 64.5 | 65.3 | 66.0 | 66.7 | 67.2 | 67.8 | 68.2 | 72.6  |
| Low Case     | 60.9  | 60.3 | 59.6 | 59.0 | 58.3 | 57.7 | 57.0 | 56.4 | 55.7 | 55.1 | 46.0  |

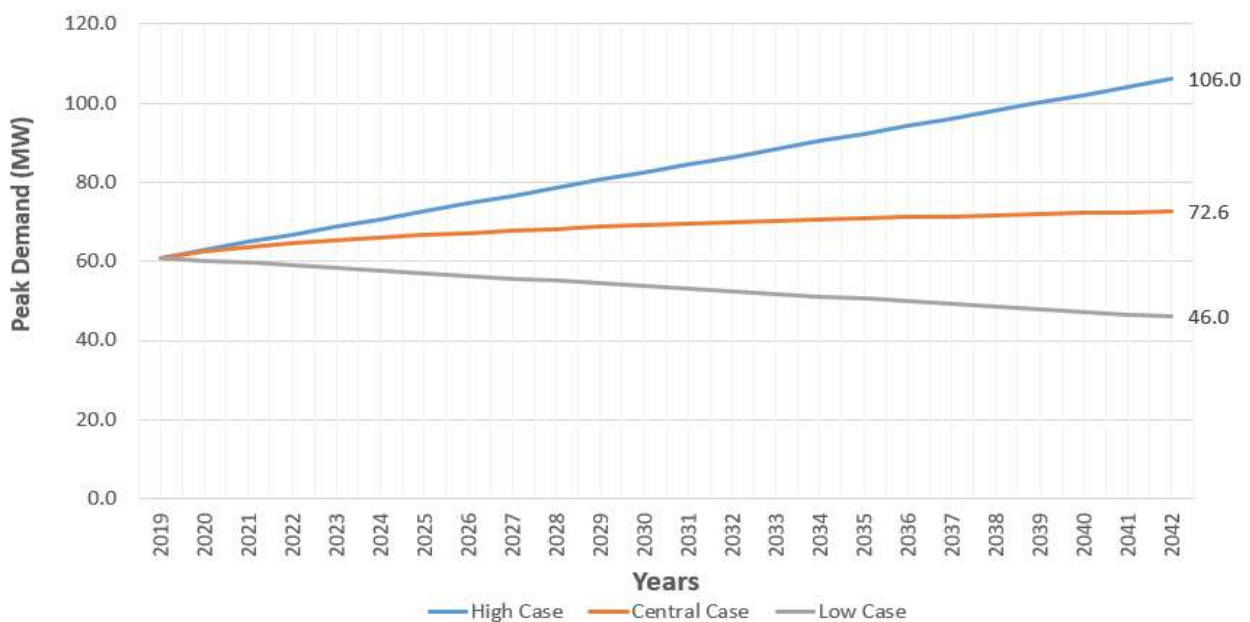

**Figure 27: Aggregate BSN and MR peak demand - Sensitivity analysis**

Table E.2 details the outcomes of the demand growth sensitivity analysis on the NPC.

**Table E.2: Demand Growth Sensitivity Analysis**

| #               | Base Case NPC (\$M) | 'Negative Growth' Case Impact  |                   | 'High Growth' Case Impact  |                   |
|-----------------|---------------------|--|-------------------|--|-------------------|
|                 |                     | Description  | Revised NPC (\$M) | Description  | Revised NPC (\$M) |
| Dev. Strategy 1 | 156.1               | The proposed investments relating to converting the existing 66kV supplies between Picton to Busselton will remain unchanged, as they remove the reliance of the Picton terminal transformers to provide supply to the region. No reactive support devices are required under this scenario.<br><br>Under a negative growth scenario, the 132kV rated double circuit between Capel and Busselton substations represents a high regret cost pathway compared to Development Strategies 2 and 3, | 142.9             | The proposed network development to meet a high growth scenario would require the completion of a third supply line between Picton and Busselton when the maximum supportable demand exceeds 84MW, which occurs in 2031.<br><br>The works will involve the construction of a new 35km 132kV single circuit between Picton and Capel, along the existing Picton-Capel 72 line corridor, in addition to resupplying of Westralian Sands substation at 132kV. The third 132kV supply into Busselton will increase the maximum supportable demand from 84MW to 118MW.  | 180.3             |
| Dev. Strategy 2 | 143.6               | The proposed investments relating to converting the existing 66kV supplies between Picton to Busselton will remain unchanged, as they remove the reliance of the Picton terminal transformers to provide supply to the region. No reactive support devices are required under this scenario  | 130.5             | The proposed network development to meet a high growth scenario would require the completion of a third supply line between Picton and Busselton when the maximum supportable demand exceeds 84MW, which occurs in 2031.<br><br>The works will involve the construction of a new 35km 132kV single circuit between Picton and Capel, along the existing Picton-Capel 72line corridor, in addition to resupplying of Westralian Sands substation at 132kV. The existing conductors on the Capel-Busselton 71 line are suitable for 132kV energisation but require a new 132kV line circuit into Capel substation.<br><br>The third 132kV supply into Busselton will increase the maximum supportable demand from 84MW to 118MW. | 171.3             |

| #               | Base Case NPC (\$M) | 'Negative Growth' Case Impact   |                   | 'High Growth' Case Impact   |                   |
|-----------------|---------------------|---|-------------------|---|-------------------|
|                 |                     | Description   | Revised NPC (\$M) | Description   | Revised NPC (\$M) |
| Dev. Strategy 3 | 148.9               | The proposed investments relating to converting the existing 66kV supplies between Picton to Busselton will remain unchanged, as they remove the reliance of the Picton terminal transformers to provide supply to the region. No reactive support devices are required under this scenario   | 136.9             | <p>The proposed network development to meet a high growth scenario would require the completion of a third supply line between Picton and Busselton when the maximum supportable demand exceeds 84MW, which occurs in 2031.</p> <p>The works will involve the construction of a new 35km 132kV single circuit between Picton and Capel, along the existing Picton-Capel 72line corridor, in addition to resupplying of Westralian Sands substation at 132kV. The existing conductors on the Capel-Busselton 71 line are suitable for 132kV energisation but require a new 132kV line circuit into Capel substation.</p> <p>The third 132kV supply into Busselton will increase the maximum supportable demand from 84MW to 118MW.</p> | 180.5             |
| Dev. Strategy 4 | 174.1               | <p>The proposed like for like replacement investments will remain unchanged. This scenario also assumes that the existing N-1 non-compliance risks relating to voltage are diminishing as a result of declining peak demand levels, thus avoiding the need to procure any NCS.</p> <p>The network will continue to be non-compliant until peak demand levels reach 46MW. Until such time, the N-1 voltage related risks will continue to be managed with the existing network control room instruction.</p> | 143.9             | <p>The proposed like for like replacement investments will remain unchanged however, high peak demand growth will require greater levels of NCS to be procured.</p> <p>Under this scenario, the procurement of NCS would increase progressively from an initial capacity of 32MW under a series of NCS contracts up until a maximum of 65MW to cater for an increase in peak demand up to 106MW. The NPC under this option is still significantly higher than the 132kV conversion options</p>  | 224.2             |

| #               | Base Case NPC (\$M) | 'Negative Growth' Case Impact  |                   | 'High Growth' Case Impact  |                   |
|-----------------|---------------------|--|-------------------|--|-------------------|
|                 |                     | Description  | Revised NPC (\$M) | Description  | Revised NPC (\$M) |
| Dev. Strategy 5 | 161.5               | <p>The proposed like for like replacement investments will remain unchanged. This scenario also assumes that the existing N-1 non-compliance risks relating to voltage are diminishing as a result of declining peak demand levels, thus avoiding the need to install additional reactive support devices</p> <p>The network will continue to be non-compliant until peak demand levels reach 46MW. Until such time, the N-1 voltage related risks will continue to be managed with the existing network control room instruction.</p> | 143.0             | <p>The proposed like for like replacement investments will remain unchanged however, a significant increase in additional reactive support devices is required to support a peak demand of 106MW at Busselton and Margaret River.</p> <p>However, thermal overload issues arise on the Capel-Busselton 71 &amp; 72 line circuits with the installation of additional reactive support devices for peak demand levels only slightly higher 73MW. This triggers the need to construct a third 66kV line from Picton to Busselton, in addition to much higher reactive support capacity at Busselton, resulting in the highest NPC option</p> | 252.7             |

## Appendix F: Discounted Options

While multiple options (including sub components) were considered in the options analysis process, only the five development strategy pathways were shortlisted, those presented in section 5. Options which were considered but ultimately discounted as they did not meet selection criteria are tabulated below.

**Table F.1: Summary of discounted options**

| Option  | Justification for discounting Option   |
|---|--|
| 1 – Do Nothing  | <p>The ‘Do Nothing’ option does not address any of the asset condition and voltage capacity issues identified within the Picton South network over the long term.</p> <p>A significant number of the Picton South 66kV assets are approaching or have already exceeded their expected replacement life, with many assets also in degraded condition. The Picton terminal transformers represent the highest risk assets in the area as they are 52 years old and both in degraded condition. These transformers are critical in providing supply to the Picton South 66kV network and are necessary to maintain N-1 system security to the region.</p> <p>The consequence of this risk will initially result in a loss of supply to approximately 46,000 customers, of which 81 are on life support), followed by a significant period of rotational load shedding, resulting in adverse impact on customers experience and reduced economic activity, widespread adverse state media attention and significant reputation risk to Western Power.</p> <p>The ‘Do Nothing’ option also does not address the existing voltage capacity limitations, resulting in a failure to meet the forecast peak demand and the inability to accommodate future growth opportunities in the region. As a result, this option is not recommended.</p> |
| 2 - A new 27km 132kV rated single circuit transmission line from Kemerton to Picton | <p>The installation of a new 132kV rated transmission line totalling approximately 27km from Kemerton to Picton substation is not expected to provide much benefit to resolving the network issues within the Picton South region.</p> <p>Although the new transmission line circuit will improve power flows into Picton as well as increase the level of reliability to the area with an additional supply line, it does not provide the voltage support at the Busselton and Margaret River, where it is needed.</p> <p>A new 132kV line from Kemerton to Picton reinforcement, along with further reinforcement at Kemerton substation would enable the demeshing of the Bunbury and Muja load areas, providing benefits of avoiding large replacement costs associated with the 86km section of line from Wokalup up to Pinjarra.</p>   |

| Option  | Justification for discounting Option   |
|---|--|
| <p>3- Splitting of the long 132kV Picton-Pinjarra-Busselton/Kemerton 81 line via a new 4.5km line section from Kemerton</p> | <p>One of the main contributing factors that results in voltage issues in the Picton South region is due to faults that occur on the long 183km 132kV supply into Busselton.</p> <p>In 2016, Western Power improved the reliability of this line through the installation of a controllable switch in the Wokalup locality. This switch was primarily installed to provide bushfire risk benefits during bushfire season by segmenting the 132kV line north of Wokalup up to Pinjarra, which reduces the line exposure by 85km. However, as the segmentation of the network reduces the system security, the open status of the switch is not recommended as a permanent arrangement.</p> <p>An option to install a new 132kV line bay and 4.5km 132kV transmission line circuit from Kemerton up to Wokalup will facilitate the permanent split of the 132kV supply into Busselton into two separate circuits, north and south of Kemerton has been investigated. At a high level, the nominal costs are expected to be circa \$7.2M.</p> <p>Splitting the 132kV supplies into two circuits will reduce the likelihood of a 132kV fault that results in voltage capacity issues within the Picton South region as it reduces the line exposure by approximately 86km. If a fault occurred on the remaining portions of the 132kV line into Busselton (approximately 98km of line exposure), the severity of the voltage excursions is essentially the same as without this new section.</p> <p>Based on the past two-year fault history, the 132kV transmission line has tripped a total of 10 times. Three of these faults occurred upstream of the Wokalup switch and towards Pinjarra substation however, only one of these faults coincided with the critical levels of demand that would have led to voltage capacity related issues. As a result, the benefit of this option is limited to reducing the line exposure.</p> <p>Lastly, Western Power is investigating strategies to demesh certain load areas to avoid large transmission line replacement costs and allow for simpler operation of the network. The Pinjarra line section is 63 years old and is 85km in length. Over the next 15-20 years, it is likely to require significant expenditure for conductor and pole replacements. With significant expenditure required to maintain this line over the long term, there is a risk that the preferred long-term pathway involves decommissioning and removal of the Pinjarra line section.</p> <p>Although the proposed reinforcement will provide benefits of reducing the line exposure, the cost benefit ratio is high. Furthermore, the existing Wokalup switch becoming redundant and there is also a risk that the Pinjarra line section may be removed over the longer term. As a result, this option has been discounted.</p> |
| <p>4 - Conversion of Picton-Pinjarra-Busselton/Kemerton 81 line into two new circuits</p>                                   | <p>This option investigated the construction of a new 132kV circuit from Kemerton to Busselton totalling approximately 75km in length. Based on the requirement of only two 132kV supplies into Busselton, a new single circuit from Kemerton to Busselton is expected to be significantly higher in cost than converting one of the existing 66kV lines, as the Picton to Capel/Westralian Sands 71 line circuit is already constructed to 132kV standard.</p> <p>Furthermore, the Busselton section of the 132kV supply into Busselton is only 19 years old, representing minimal optimisation opportunity to rebuild this line as either a new 132kV single or as a double circuit (for strategic benefit). As a result, this option has been discounted.</p>   |

| Option  | Justification for discounting Option  |
|---|---|
| 5 - Refurbishment of the Picton Terminal transformers | <p>Most of the investments proposed under the 132kV conversion options are initially triggered by the need to mitigate the condition related issues with both Picton terminal transformers. Although converting one of the existing 66kV lines to 132kV will provide additional capacity beyond the forecast peak demand, the investments to address voltage capacity constraints in the area can be delivered independently.</p> <p>The option to refurbish the Picton terminal transformers represents an opportunity to defer large stages of works that are proposed to address the system security related risks associated with transformers, particularly for the 132kV conversion options.</p> <p>An investigation was performed into the feasibility of transformers refurbishment. The findings of this investigation determined that this option is not feasible and was discounted for the following reasons:</p> <ul style="list-style-type: none"> <li>• Both transformers are 52 years old and have almost reached their expected mean replacement life of 55 years old. Refurbishment of aged transformers provides diminishing benefits as some components are unable to be refurbished.</li> <li>• Major refurbishment facilities do not exist in Western Australia. Each transformer refurbishment would need to be performed off site at an East Coast facility, representing risks associated with transportation.</li> <li>• During the period of refurbishment (estimated at 6-9 months), the security and supply to the 46,000 customers in the region is at risk should the remaining transformer failure. This scenario is also likely to result in out of merit order costs.</li> <li>• Manufacturers do not provide warranties for the extension of service life following refurbishment treatments. Rather, an indicative service life extension of 5 years is commonly provided.</li> <li>• Refurbished transformers may fail prematurely, which essentially diminishes the value of the refurbishments. Furthermore, the accelerated works may be performed under emergency conditions and incur higher costs.</li> </ul> <p>The cost of each refurbishments was estimated at \$0.8M (based cost, including transport), which considering the age of the transformers, would be cost prohibitive and provide very limited deferment savings.</p> |

| Option                              | Justification for discounting Option   |
|-------------------------------------|--|
| 6 – Installation of battery systems | <p>As an alternative to addressing the existing voltage capacity related constraints in the Picton South region through the proposed STATCOM and capacitor bank equipment, Western Power has investigated the installation of battery system solutions – both at the transmission and distribution level.</p> <ul style="list-style-type: none"> <li>• <i>Transmission connected battery option:</i> To achieve the desired impact, a 30MW/120MWh battery system would be required at a cost of circa \$65M. (We note that this option could also be a substitute for NCS which applies only to Option 4 – not being the preferred option)</li> <li>• <i>Distribution connected battery option:</i> A number of (circa 200) grid scale battery systems connected on the Busselton or Margaret River LV distribution networks could be used to offset the demand at Busselton and Margaret River substations during peak demand periods at a cost of ~\$80M. Notably, although batteries assist with voltage stability, they will not address asset condition issues being the principal driver for this investment. Notwithstanding the costs associated with this option, there is potential for other benefits including deferring long-term distribution network investment coupled with the potential for unregulated revenue. However, the regulatory framework is yet to evolve to support options of this nature.</li> </ul> <p>In comparison to the proposed STATCOM /capacitor bank solution (\$15.4M), battery systems are cost prohibitive.</p> |
| 7 – Microgrid systems               | <p>At a high level, microgrid systems have also been investigated as an alternative; however, asset condition issues are not addressed under this type of solution. From a cost perspective:</p> <ul style="list-style-type: none"> <li>• a single large microgrid, supplying a network with a peak demand of ~26MW or multiple smaller sized microgrids would be required to address the voltage capacity related issues</li> <li>• the microgrid would need to be designed using a combination of renewable generation and batteries to support energy demand without reliance on the grid.</li> </ul> <p>Accordingly, the cost of a microgrid solution is expected to be significantly higher than battery systems, thus being cost prohibitive. In addition, there are a number of technical challenges involved with microgrid solutions and therefore this option has been discounted.</p>   |



# Appendix G: Picton South Network Diagrams

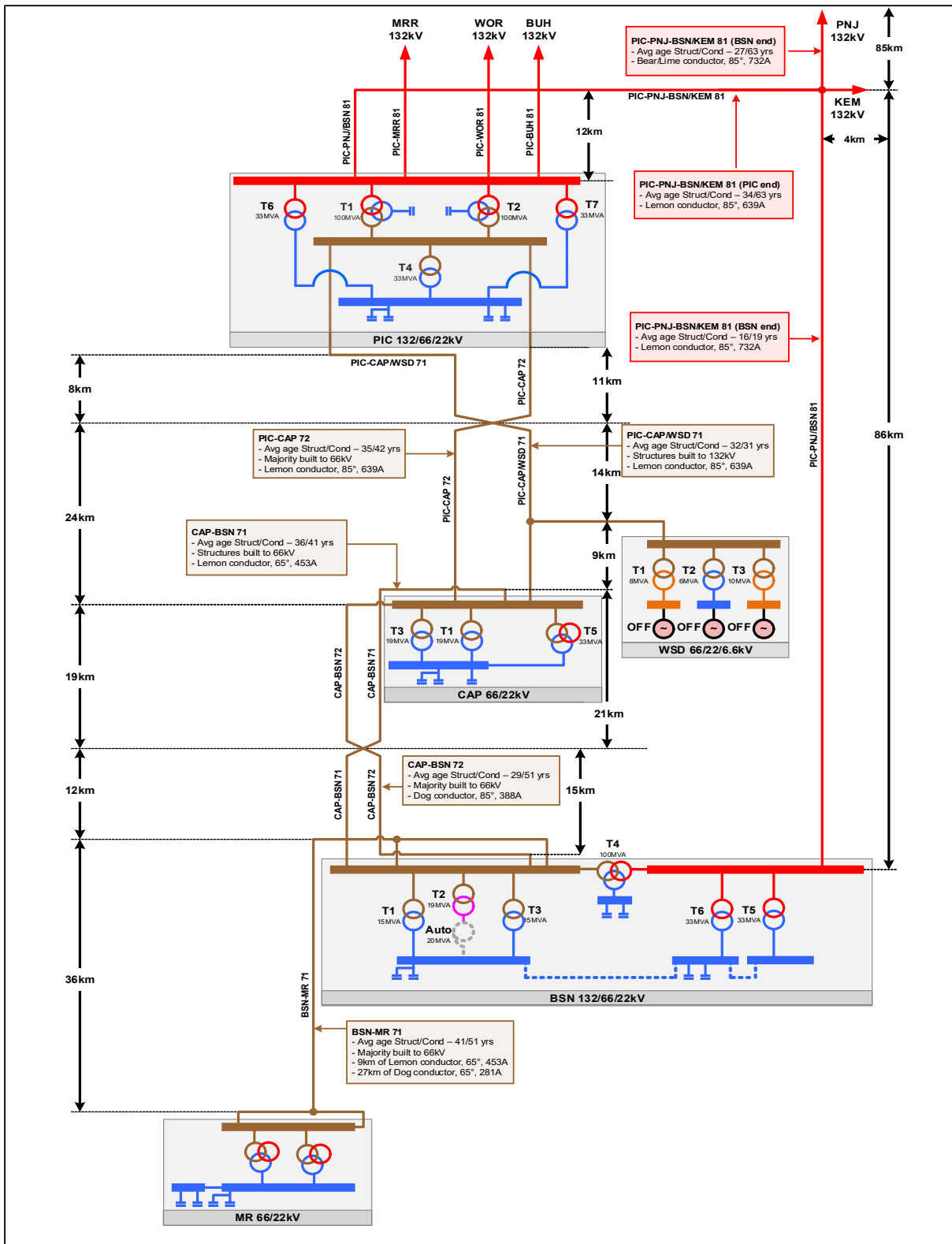

Figure 28: Picton South Network - Existing

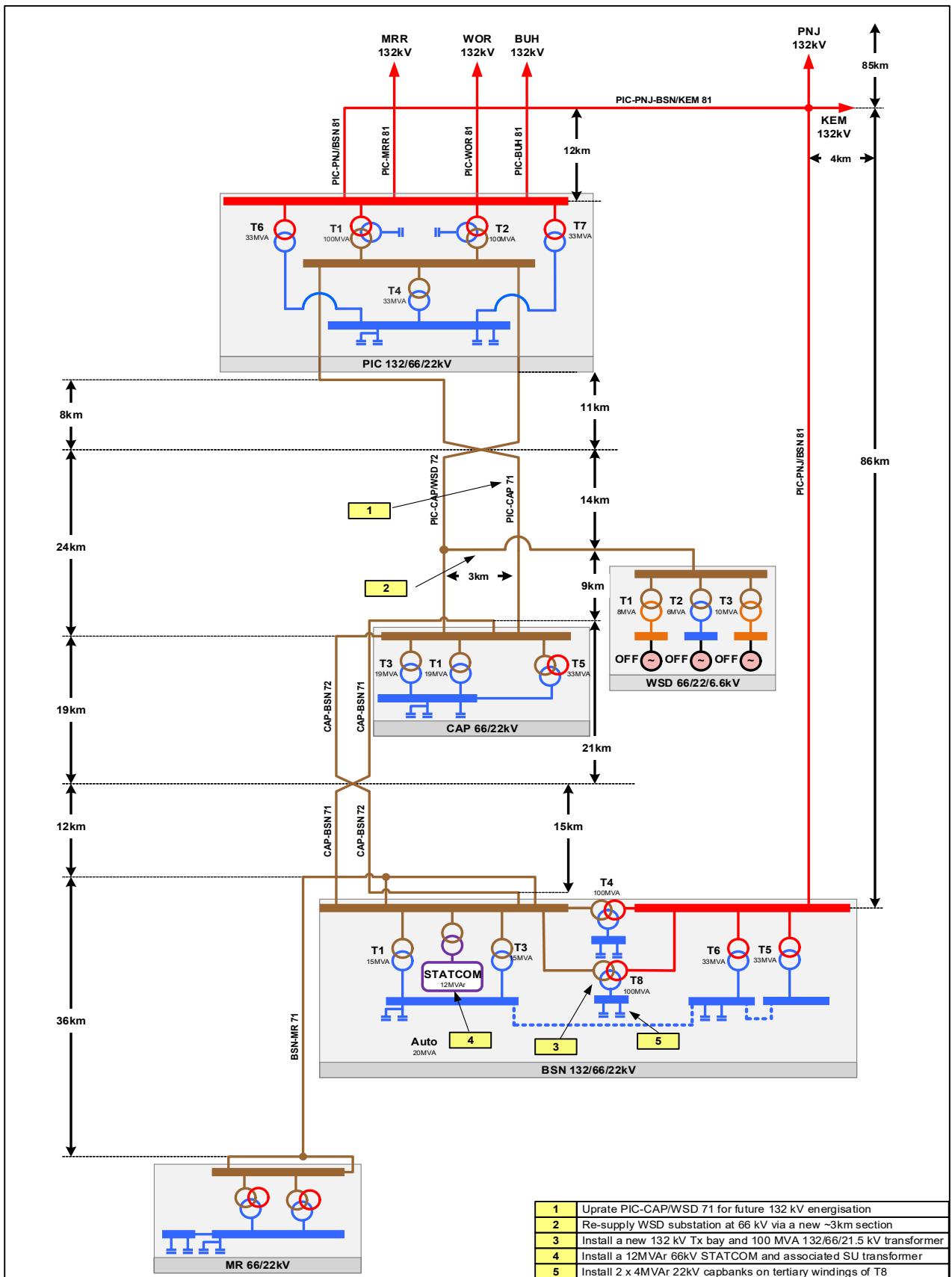

Figure 29: Picton South Network – Completion of Stage 1 works

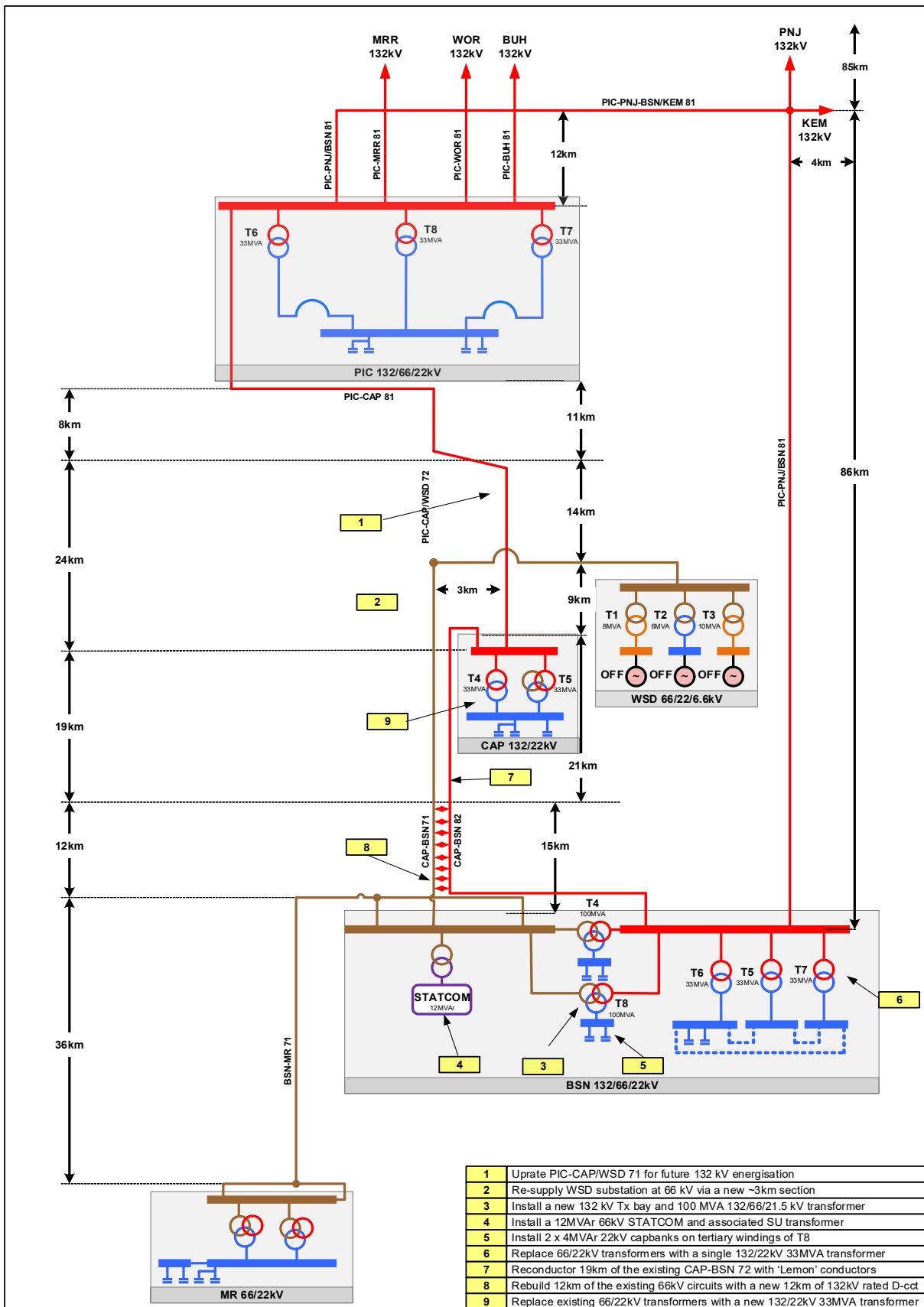

Figure 30: Picton South Network – Final Configuration

## Appendix H: Existing and Proposed Fault Levels

Table H.1 highlights the existing and proposed fault levels throughout the Picton South region for the recommended Development Strategy 2. Increases in fault levels are material at Busselton and Margaret River 66kV substations upon the completion of all works however, all transmission equipment is adequately rated at these higher proposed fault levels.

Furthermore, detailed distribution protection path studies have been performed to determine the impact to the distribution network. These studies have identified the need for minor distribution protection works involving protection setting changes and uprating several bays to a higher rating to achieve adequate grading margins, sensitivity and fault ratings.

**Table H.1: Picton South – Existing and proposed fault levels**

| Network Configuration                        | Fault conditions | Fault type | PIC 66kV | PIC 132kV | WSD 66kV | CAP 66kV | BSN 66kV | BSN 132kV | MR 66kV |
|--|------------------|------------|----------|-----------|----------|----------|----------|-----------|---------|
| Existing network                             | Max              | 3P (kA)    | 9.6      | 11.4      | 4.8      | 5.3      | 4.3      | 1.7       | 1.6     |
|  | Max              | 1PG (kA)   | 12.0     | 10.2      | 3.8      | 4.8      | 5.2      | 1.2       | 1.2     |
|  | Min              | 3P (kA)    | 5.2      | 4.6       | 3.9      | 3.2      | 1.9      | 1.5       | 1.3     |
|  | Min              | 1PG (kA)   | 6.42     | 4.1       | 3.2      | 2.7      | 2.5      | 1.0       | 1.0     |
| Completion of recommended works – Stage 1    | Max              | 3P (kA)    | 9.4      | 11.4      | 4.3      | 5.5      | 4.7      | 2.6       | 1.6     |
|  | Max              | 1PG (kA)   | 11.9     | 11.0      | 3.6      | 5.7      | 6.4      | 2.7       | 1.3     |
|  | Min              | 3P (kA)    | 5.2      | 4.8       | 3.6      | 3.4      | 2.2      | 0.8       | 1.3     |
|  | Min              | 1PG (kA)   | 6.4      | 4.6       | 3.0      | 3.6      | 3.0      | 1.0       | 1.1     |
| Completion of Development Strategy 2 pathway | Max              | 3P (kA)    | 9.0      | 11.8      | 3.8      | 4.1      | 5.8      | 4.5       | 1.7     |
|  | Max              | 1PG (kA)   | 11.5     | 11.7      | 2.8      | 3.4      | 7.7      | 4.4       | 1.3     |
|  | Min              | 3P (kA)    | 4.3      | 4.8       | 3.2      | 1.6      | 3.9      | 1.5       | 1.5     |
|  | Min              | 1PG (kA)   | 5.4      | 4.6       | 2.4      | 1.2      | 4.8      | 1.0       | 1.1     |

## Appendix I: Resupply of WSD

The Westralian Sands substation is a 66kV substation supplied by the existing Picton-Capel/Westralian Sands 71 line. The substation was commissioned in 1987. The substation has three 66kV power transformers of differing capacity and secondary voltages, as shown in Figure 31.

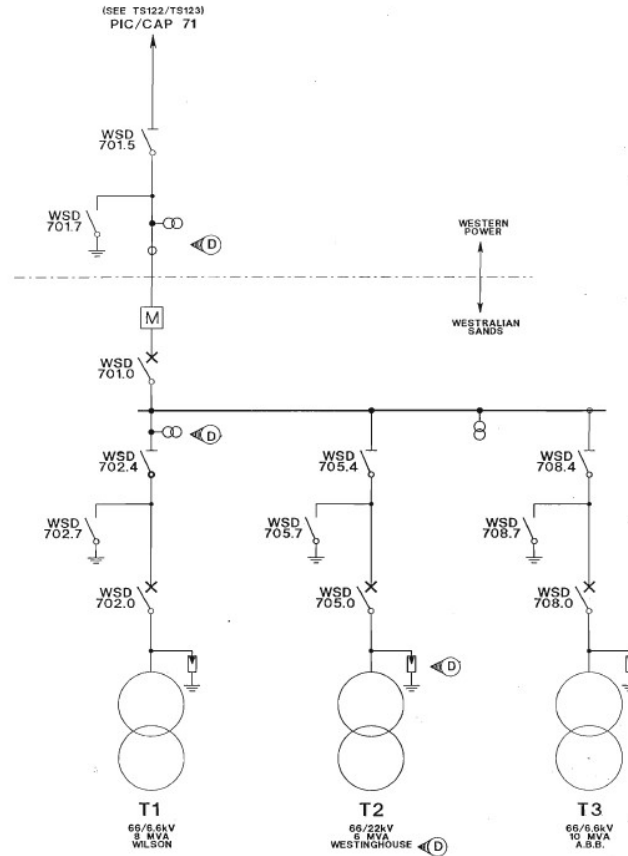

Figure 31: Westralian Sands SLD

Despite the long-term view in Figure 6 indicating resupplying Westralian Sands substation at 22kV, alternative supply arrangements have been investigated further to support the network development under each of the 132kV development strategies presented in this paper.

A range of likely supply arrangements, along with their triggers, have been identified and are discussed in detail in Table I.1. These include:

1. Resupply at 132kV
2. Resupply at 66kV
3. Resupply at 22kV
4. Relinquishment of supply

**Table I.1: Resupply of Westralian Substation – Identified triggers**

| Triggered by  | Trigger Category           | Trigger Description   |
|---------------|----------------------------|---|
| Western Power | Asset Replacement          | In the future, the cost to maintain and replace the assets associated with the Capel-Busselton 71 circuit may outweigh the cost to decommission these assets and convert the Westralian Sands substation to either 22kV or 132kV. |
| Western Power | Network Upgrade            | A third 132kV supply into Busselton will trigger upgrading approximately 21km of the Capel-Busselton 71 circuit to 132kV and resupplying Westralian Sands at 132kV  |
| Customer      | Network Upgrade            | Future expansion requirements may trigger the need to resupply the customer at 132kV.   |
| Customer      | Asset Replacement          | Although the substation was commissioned in 1987, the replacement of 66kV assets may trigger the opportunity to replace asset at a higher voltage and convert the substation to 132kV.  |
| Customer      | Customer relinquish supply | The Customer may choose to relinquish its supply in the future, which represents a risk to the construction of any new infrastructure and therefore, the least cost option to resupply the substation is preferred.               |

Taking the above potential triggers and existing substation assets into consideration, a cost analysis has been performed to help determine the most cost-effective supply arrangements for Westralian Sands substation. The costings and associated risks with each supply arrangement is detailed in Table I.2.

Resupplying Westralian Sands at 66kV results in the lowest nominal cost, as shown in in Table I.2.

**Table I.2: Resupply Westralian Sands substation options**

| Supply Arrangement | High Level Scope  | Real Cost (\$M) <sup>47</sup> | Risks  |
|--------------------|---|-------------------------------|--|
| Resupply at 132kV  | <ul style="list-style-type: none"> <li>Installation of a new 132/66kV 15MVA transformer and associated</li> <li>New 132kV line circuit</li> <li>Extension of substation site</li> </ul> | \$5.6                         | <ul style="list-style-type: none"> <li>Space limitations exist to accommodate an additional transformer. This Substation site requires extension to accommodate an additional transformer.</li> <li>Reliability of supply to the substation is reduced with the installation of a single 132/66kV transformer.</li> <li>Lower levels of operational flexibility during the maintenance of the proposed single 132/66kV transformer.</li> </ul> |
| Resupply at 66kV   | <ul style="list-style-type: none"> <li>Construction of a 3km new transmission line section connecting the Capel-Busselton 72 circuit to Westralian Sands</li> </ul>                     | \$4.1                         | <ul style="list-style-type: none"> <li>Potential environmental risks associated with clearing of natural habitat for the endangered black cockatoo and ringtail possum for the proposed new line. However, this risk has been assessed as minor and can be designed out.</li> </ul>  |

<sup>47</sup> Including risk, labour on costs and locality factor

| Supply Arrangement       | High Level Scope   | Real Cost (\$M) <sup>47</sup> | Risks   |
|--------------------------|--|-------------------------------|---|
| Resupply at 22kV         | <ul style="list-style-type: none"> <li>Construction of a new 10km overhead 22kV distribution circuit from the Capel substation</li> <li>Replace the two existing 66/6.6kV transformers with new 22.6/6kV 10MVA transformers and associated 22kV circuit breakers</li> <li>Energise the existing 66kV busbar at 22kV</li> </ul> | \$5.0                         | <ul style="list-style-type: none"> <li>Potential environmental risks associated with clearing of natural habitat and wetland areas surrounding Capel substation.</li> <li>Power quality issues associated with significant motor loads may trigger the need to install harmonic filters and power factor correction at the site. This may also trigger the need for an additional 22kV line, if further detailed studies identify significant voltage constraints.</li> <li>The transformer replacement and other works represent a significant disruption to Iluka's operations.</li> <li>Transferring the supply to Capel substation will increase the peak demand levels very close to the future N-1 substation rating of 39MVA. Minor demand increases in the future will trigger the need for an additional transformer.</li> </ul> |
| Relinquishment of supply | <ul style="list-style-type: none"> <li>Not applicable</li> </ul>   | n/a                           | <ul style="list-style-type: none"> <li>Any infrastructure to support the resupply of the substation at 22kV, 66kV or 132kV will be sunk costs should the customer no longer require a supply</li> </ul>   |

Although resupplying Westralian Sands at 66kV, is the least nominal cost, it does not consider the potential to decommission the remaining 66kV line assets and avoid future CAPEX/OPEX costs.

To verify this, further studies were performed to compare the 22kV or 132kV supply options that included the decommissioning and removing the remaining of 68km of 66kV transmission line assets and associated CAPEX/OPEX impacts. Sensitivity studies highlight that prior to 2054, it was still more cost effective to resupply the Westralian Sands at 66kV. Beyond this period, large volumes of conductor replacements are forecast on these lines. As a result, Western Power has applied this supply arrangement to each of the 132kV development strategies.

The early resupply of Westralian Sands at 66kV also provides network security benefits under a double Picton terminal transformer contingency. Once resupplied, only minimal works are required to energise Capel to 132kV should a second Picton terminal transformer fail before a replacement can be implemented. This contingency plan significantly reduces the amount of load shedding that would be required and therefore supports the resupply of Westralian Sands being completed as early as possible.

Although the 66kV supply option is presented as the preferred supply arrangement in this Options Paper, if any of the triggers described in Table I.1 should eventuate, Western Power will re-evaluate the most suitable supply arrangement that meets both the network and customer requirements. Any changes to Westralian Sands supply arrangement are not expected to have any material impact to the development of any of 132kV development strategies.

## Appendix J: Capel and Busselton 132kV Line Conversion Options

Although the works to upgrade the supplies between Capel to Busselton to 132kV are common to all the 132kV development strategies, they do not form part of the recommended works to progress under this Options Paper. Any proposed 132kV network conversion in the area is expected to require significant capital expenditure, which may be subject to future Regulatory Tests.

In order to provide equivalency in comparing options, a high-level assessment into the most suitable conversion pathway has been assessed and applied to the staged 132kV development strategies.

The proposed 132kV conversion between Picton and Capel is relatively straightforward as the existing Picton-Capel/Westralian Sands 71 line circuit has already been constructed to 132kV standard, as shown in Table 2.4. Minimal expenditure is therefore required to uprate and operate this line circuit at 132kV.

Conversely, the supplies between Capel and Busselton have multiple condition issues and conductor rating limitations that create a range of alternative upgrade options that can be categorised under three broad network reinforcement options:

- Construction of a new 132kV rated single circuit
- Construction of a new 132kV rated double circuit
- Upgrading (reconductoring) of one of the existing 66kV Capel to Busselton circuits to 132kV

Considering the long-term view of the network development, the peak demand forecast does not currently support a third 132kV supply into Busselton. The construction of a double circuit line between Capel and Busselton could only be justifiable if it represented a lower overall cost when compared to a like for like replacement plan.

With consideration to the above broad themes, long term peak demand forecasts and asset condition information relating to the existing transmission line assets, Western Power has developed the following three conversion options:

- New 12km 132kV double circuit section and reconductoring 19km from Capel
- Construction of a new 33km 132kV rated single circuit
- Reconductor and uprate existing Capel-Busselton 72 line circuit

An overview of the network topology and a high scope of the works is shown under each option.

It is important to note that as the triggers for these investments occur, together with input from key stakeholders, local Shires and residents, Western Power expects to carry out more detailed and updated assessments to support the network development options between Capel and Busselton.



**Table J.1: High level 132kV conversion options between Capel and Busselton substation – Option A**

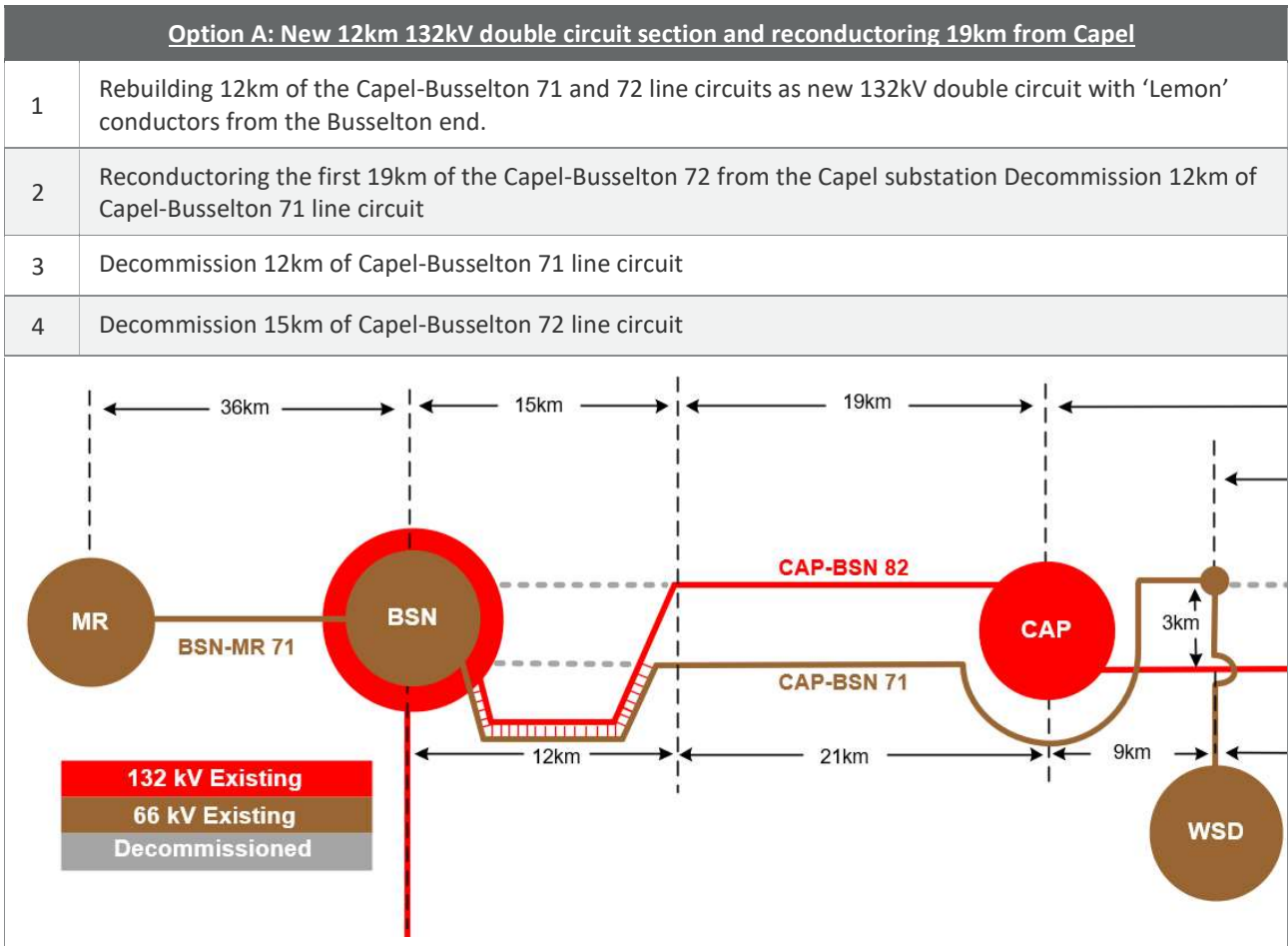

**Table J.2: High level 132kV conversion options between Capel and Busselton substation – Option B**

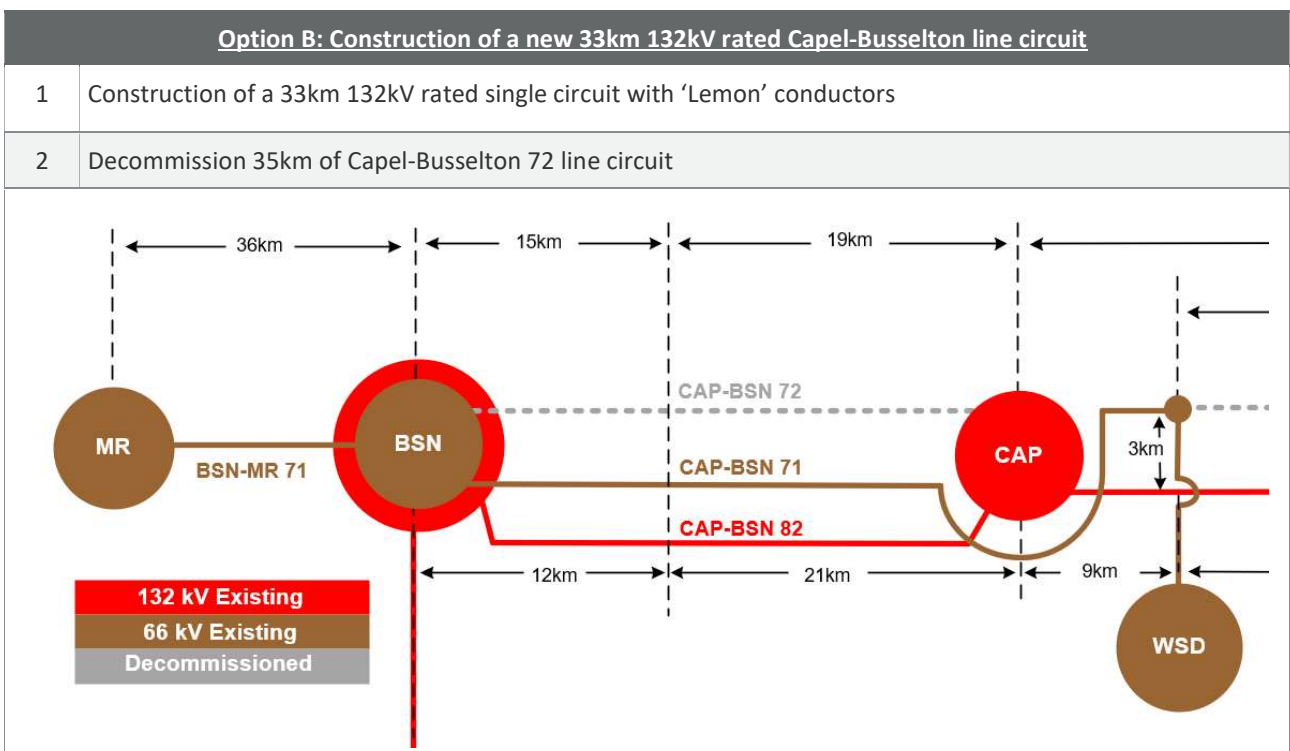

**Table J.3: High level 132kV conversion options between Capel and Busselton substation – Option C**

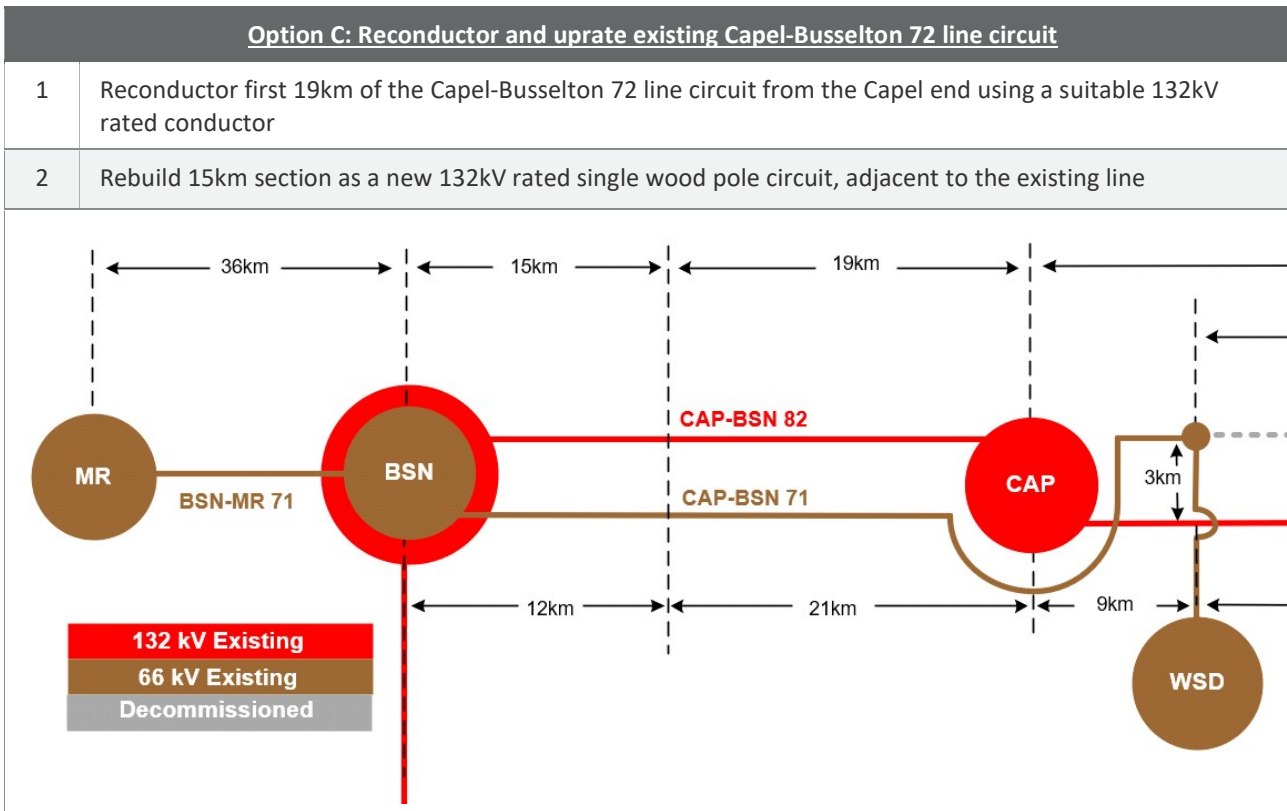

**Table J.4: High level cost analysis for proposed 132kV conversion sub-options**

| Option | Option Description  | NPC (\$M) |
|--------|---|-----------|
| A      | Rebuild 12km section and reconductor first 19km from Capel          | 43.9      |
| B      | Construction of a new 33km 132kV rated Capel-Busselton line circuit | 57.7      |
| C      | Reconductor and uprate existing Capel-Busselton 72 line circuit     | 44.9      |

The result of the cost analysis presented in Table J.4 highlight that option A presents the lowest overall NPC to convert the network between Capel to Busselton to 132kV voltage. Considering the broad assumptions used to perform the evaluation and maturity level of the cost estimates, the differences in cost between options A and C is minimal.

As there is only minimal difference in the costings between each option, Western Power has also used other qualitative methods to support the selection of option A as the preferred 132kV conversion pathway between Capel and Busselton for each of the staged 132kV development strategies within this Options Paper.

In addition of being the lowest cost option, Option A provides additional benefits that have been assessed on a qualitative basis in Table J.5. Most notably, option A presents the lowest cost pathway to transition to a third 132kV supply into Busselton.

**Table J.5: Qualitative assessment of conversion options**

| Criteria                   | Option A  | Option B   | Option C   | Preferred |
|----------------------------|---|--|--|-----------|
| Optimised network plan     | 67 and 48 wood poles within the southern section of the Capel-Busselton 71 and 72 line are currently 52 and 42 years old, respectively. These will be replaced by proposed double circuit section.<br><br>Additionally, a number of aged poles are expected to be replaced when the line is upgraded to heavier conductors. | Addresses all asset condition issues on the Capel-Busselton 72 line through decommissioning;<br><br>Does not address any condition issues on the Capel-Busselton 71 line | A number of aged poles are expected to be replaced when the line is upgraded to heavier conductors.  | Option A  |
| Provides strategic value   | Represents the lowest cost option for providing three 132kV supply lines into Busselton, through an extension of the proposed double circuit.   | Aligns with long term view but is higher in NPC  | Aligns with long term view but is higher in NPC but is marginally higher in NPC. CAPEX/OPEX over multiple asset renewal cycles is expected to be higher. | Option A  |
| Asset base rationalisation | Reducing the overall asset base, through the decommission of 27km of transmission line assets, Overall reduction in asset base will lead to lower levels of long term CAPEX/OPEX expenditure  | Depending on the new line route distance, overall asset base may change however, this is expected to be minimal.   | Effectively no change in asset base  | Option A  |
| Construction outages       | A new double circuit section will be constructed in a new corridor, with minimal construction outages expected to cut in the new line.<br><br>A significant number of construction outages are expected for the reconductoring of the first 19km of the Capel-Busselton 72 line.  | A new 132kV rated circuit will be constructed in a new corridor, with fewer construction outages expected to cut in the new line.  | A large number of construction outages are expected for the reconductoring of the first 19km of the Capel-Busselton 72 line.                             | Option B  |

| Criteria             | Option A   | Option B   | Option C  | Preferred |
|----------------------|--|--|---|-----------|
| Environmental impact | The new double circuit section will require a new corridor that will have some environmental impacts however, the net impacts are expected to be lower over the long term. | <p>A new 132kV circuit will require a new corridor that is expected to have significant environmental impacts however, this new line will facilitate the decommissioning of the existing Capel-Busselton 72 line.</p> <p>With approximately 5km of the Capel-Busselton 72 line traverses through the Tuart State Forest, slight net environmental impacts are expected</p> | The replacement of poles due to reconductoring is likely to occur with minor offsets to the existing line, which may result in minor environmental impacts. | Option C  |

## Appendix K: Network Control Services - Assumptions

**Table K.1: Network Control Service financial assessment**

| Parameter | Cost (\$ 2018/19) | Requirement | Annualised Growth (%) | Assessment Period       | Base Cost (\$M) |
|-----------|-------------------|-------------|-----------------------|-------------------------|-----------------|
| Fixed     | \$126,683/MW pa   | 30MW        | 0.00%                 | 10 Years (2022 to 2031) | \$43.3          |
| Variable  | \$108/MWh         | 362h pa     | 0.56%                 |                         | \$13.7          |
| Total     | -                 | -           | -                     | -                       | \$57.0          |

Table K.1 presents the financial analysis of procurement of NCS over a 21 year period (2022 to 2042), with the following assumptions:

- For the purposed of the Options Paper costing, and availability of accurate costings, the NCS contract assumes the procurement of generation. However, the procurement of Demand Side Management NCS contract can provide similar outcomes.
- A 30MW NCS capacity is assumed over the 10-year contract from 2021. The amount of NCS generation capacity procured also includes a portion of capacity that provides a margin slightly above the NCS required to cater for forecast peak demand.
- An NCS contract is assumed to be established in the 2022 year at the earliest.
- A subsequent NCS contract will need to occur beyond 2031. By this time, the capital cost of the generator is expected to be fully paid off with future NCS contracts to only include operational and maintenance costs. However, as there is too much uncertainty on what the fixed and variable cost inputs would be, these costs have been excluded from the costings.
- The 2019/20 reserve capacity<sup>48</sup> price (RCP) is CPI adjusted for the assessed timeframe;
- The RCP forms only those costs attributable to the fixed portion of the NCS contract;
- The variable cost is based on a gas turbine variable contracted price of \$150/MWh less a \$42.2/MWh market balancing price, calculated based on historical dispatch costs for the Mungarra Gas Turbines, as provided in the AEMO 2018/19 ancillary services<sup>49</sup> report;
- Variable costs are CPI adjusted for the assessed timeframe;
- Costs assume the NCS is dispatched pre-contingent at lower levels of demand than the actual stability limit, which leads to higher operating time and associated costs;
- Costs do not consider any scope of works or costs for connection at Busselton or Margaret River;
- An NCS Proponent may receive capacity credits to partially offset the fixed costs. However, as this is unknown, it has not been included in the costings; and
- NCS cost assessment assumes a natural gas pipeline of adequate capacity is available to supply a gas turbine generator.

<sup>48</sup> <http://www.aemo.com.au/Electricity/Wholesale-Electricity-Market-WEM/Reserve-capacity-mechanism/Certification-of-reserve-capacity>

<sup>49</sup> <https://www.aemo.com.au/-/media/Files/Electricity/WEM/Data/System-Management-Reports/2018/2018-Ancillary-Services-Report.pdf>

## Appendix L: Technical Rules Requirements

Western Power has security, reliability and quality of supply obligations defined in the Technical Rules (December 2016 – Rev 3) and identified in Chapter 12 of the Electricity Networks Access Code (2004)

The Technical Rules establish the planning criteria that Western Power applies across the SWIS. Western Power owned substations in the Picton South region are planned under the N-1 criterion.

Table L.1 highlights the key obligations under the N-1 criterion that the Picton South network is currently failing to meet.

**Table L.1: N-1 Criterion - Planning requirements**

| Technical Rules Clause                         | Technical Requirement  |
|--|--|
| 2.5.2.2(c) - N-1 Criterion                     | Following the loss of the <i>transmission element</i> , the <i>power system</i> must continue to operate in accordance with the <i>power system</i> performance standards specified in clause 2.2.   |
| 2.2.9 - Short Term Voltage Stability           | Short term <i>voltage stability</i> is concerned with the <i>power system</i> surviving an initial disturbance and reaching a satisfactory new steady state.<br><br>Stable <i>voltage</i> control must be maintained following the most severe <i>credible contingency</i> event.  |
| 2.2.11 - Long Term Voltage Stability           | Long term <i>voltage stability</i> includes consideration of slow dynamic processes in the <i>power system</i> that are characterised by time constants of the order of tens of seconds or minutes.<br><br>The long term <i>voltage stability</i> criterion is that the <i>voltage</i> at all locations in the <i>power system</i> must be stable and <i>controllable</i> following the most onerous post-contingent system state following the occurrence of any <i>credible contingency</i> event under all credible <i>load</i> conditions and <i>generation</i> patterns.  |
| 2.3.8 - Determination of Power Transfer Limits | The <i>Network Service Provider</i> must assign, on a request by a <i>User</i> or <i>System Management</i> , <i>power transfer</i> limits to <i>equipment</i> forming part of the <i>transmission and distribution</i> systems. The assigned <i>power transfer</i> limits must ensure that the system performance criteria specified in clause 2.2 are met and may be lower than the <i>equipment</i> thermal ratings. Further, the assigned <i>power transfer</i> limits may vary in accordance with different <i>power system</i> operating conditions and, consistent with the requirements of these <i>Rules</i> , should to the extent practicable maximise the <i>power transfer</i> capacity made available to <i>Users</i> .<br><br>The <i>power transfer</i> assessed in accordance with clause 2.3.8(a) must not exceed 95% of the relevant rotor angle, or other stability limit as may be applicable, whichever is the lowest. |

# Appendix M: Western Power Reference Documents

Technical Rules

Electricity Networks Access Code 2004

Applications and Queuing Policy

Investment Governance Framework